

Interface

FORCE MEASUREMENT SOLUTIONS.

Installation & User Manual

INF1

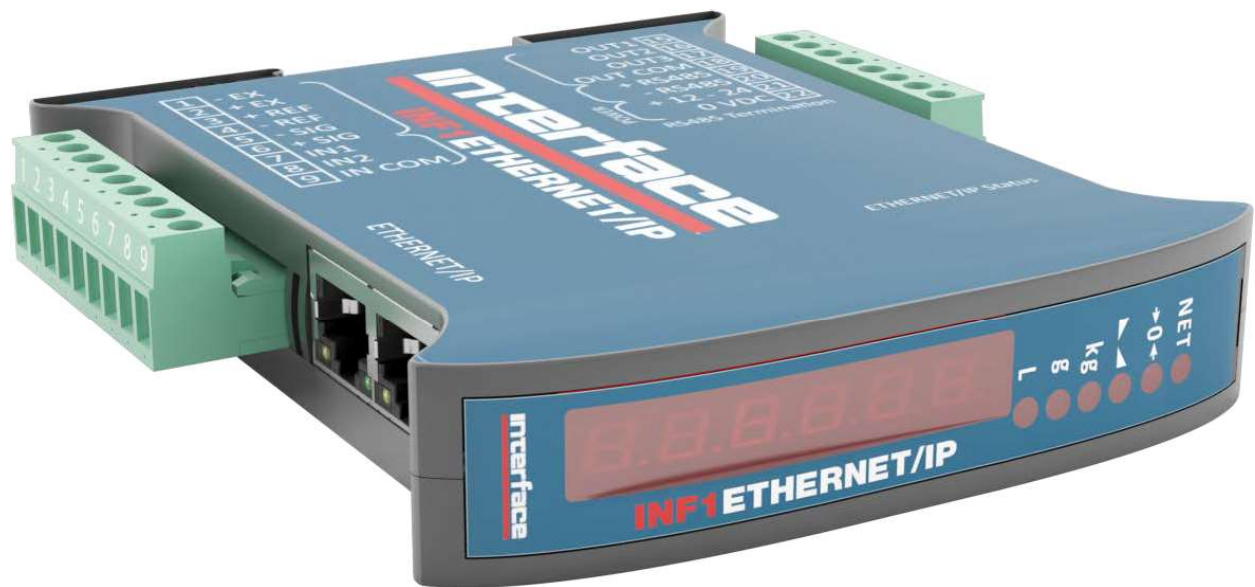

INF1 Installation & User Manual

KEY TO SYMBOLS

Below are the symbols used in this manual to draw the reader's attention:



Warning! Risk of electrocution.



Warning! This operation must be performed by skilled workers.



Further information.

TABLE OF CONTENTS

USER WARNINGS	6
RECOMMENDATIONS FOR INSTRUMENT INSTALLATION	6
RECOMMENDATIONS FOR LOAD CELL INSTALLATION	6
LOAD CELL INPUT TEST (QUICK ACCESS)	8
LOAD CELL TESTING	8
MAIN INSTRUMENT SPECIFICATIONS	9
TECHNICAL SPECIFICATIONS	10
ELECTRICAL CONNECTIONS	11
BASIC INFORMATION	11
WIRING DIAGRAM	11
<i>INF1 - INF485</i>	11
<i>INF1 (other models)</i>	12
LED AND KEYS FUNCTIONS	13
MENU MAP	14
SETPOINT	14
SYSTEM PARAMETERS	14
INSTRUMENT COMMISSIONING	15
PROGRAMMING OF SYSTEM PARAMETERS	16
THEORETICAL CALIBRATION	16
<i>MAXIMUM CAPACITY</i>	17
<i>TARE WEIGHT ZERO SETTING</i>	17
<i>ZERO VALUE MANUAL ENTRY</i>	17
REAL CALIBRATION (WITH SAMPLE WEIGHTS)	18
FILTER ON THE WEIGHT	19
<i>ANTI PEAK</i>	19
ZERO PARAMETERS	20
<i>RESETTABLE WEIGHT SETTING FOR SMALL WEIGHT CHANGES</i>	20
<i>AUTOMATIC ZERO SETTING AT POWER-ON</i>	20
<i>ZERO TRACKING</i>	20
SETTING UNITS OF MEASURE	21
<i>DISPLAY COEFFICIENT</i>	21
INPUT AND OUTPUT CONFIGURATION	23
SEMI-AUTOMATIC TARE (NET/GROSS)	24
PRESET TARE (SUBTRACTIVE TARE DEVICE)	25
SEMI-AUTOMATIC ZERO (ZERO-SETTING FOR SMALL VARIATIONS)	25
PEAK	26
ANALOG OUTPUT	26
SERIAL COMMUNICATION SETTING	28
<i>RS485 SERIAL COMMUNICATION</i>	29
<i>DIRECT CONNECTION BETWEEN RS485 AND RS232 WITHOUT CONVERTER</i>	29
TEST	30

SETPOINT PROGRAMMING	31
ALARMS	32
COMMUNICATION PROTOCOLS	33
CONTINUOUS FAST WEIGHT TRANSMISSION PROTOCOL	33
ASCII BIDIRECTIONAL PROTOCOL	34
SETPOINT PROGRAMMING	34
<i>SETPOINT STORAGE IN EEPROM MEMORY</i>	35
READING WEIGHT, SETPOINT AND PEAK (IF PRESENT) FROM PC	35
SEMI-AUTOMATIC ZERO (ZERO-SETTING FOR SMALL VARIATIONS)	36
SWITCHING FROM GROSS TO NET WEIGHT	36
SWITCHING FROM NET TO GROSS WEIGHT	36
READING OF DECIMALS AND DIVISION NUMBER	37
TARE ZERO-SETTING	37
REALCALIBRATION(WITHSAMPLEWEIGHT)	38
KEYPAD LOCK (BLOCK THE ACCESS TO THE INSTRUMENT)	38
KEYPAD UNLOCK	38
DISPLAY AND KEYPAD LOCK	39
CHECK-SUM CALCULATION	39
MODBUS-RTU PROTOCOL	40
FUNCTIONSSUPPORTEDINMODBUS	40
COMMUNICATION ERROR MANAGEMENT	42
LIST OF AVAILABLE REGISTERS	42
POSSIBLE COMMANDS TO BE SENT TO COMMAND REGISTER (40006)	46
<i>ANALOG OUTPUT SETTING</i>	46
<i>REAL CALIBRATION COMMANDS (WITH SAMPLE WEIGHTS)</i>	46
COMMUNICATION EXAMPLES	47
CANOPEN	50
TECHNICAL SPECIFICATIONS AND CONNECTIONS	50
INSTRUMENT SETUP	50
PC/PLC SETUP	51
POSSIBLE COMMANDS TO BE SENT TO THE COMMAND REGISTER	53
<i>REAL CALIBRATION COMMANDS (WITH SAMPLE WEIGHTS)</i>	54
DEVICENET	55
TECHNICAL SPECIFICATIONS AND CONNECTIONS	55
INSTRUMENT SETUP	55
PC/PLC SETUP	56
POSSIBLE COMMANDS TO BE SENT TO THE COMMAND REGISTER	58
<i>REAL CALIBRATION COMMANDS (WITH SAMPLE WEIGHTS)</i>	59

CC-LINK	60
TECHNICAL SPECIFICATIONS AND CONNECTIONS	60
INSTRUMENT SETUP	60
PC/PLC SETUP	61
POSSIBLE COMMANDS TO BE SENT TO THE COMMAND REGISTER	63
<i>REAL CALIBRATION COMMANDS (WITH SAMPLE WEIGHTS)</i>	<i>64</i>
ETHERNET TCP/IP	65
TECHNICAL SPECIFICATIONS	65
INSTRUMENT SETUP	65
PC SETUP	67
DIAGNOSTIC	68
WEBSITE	70
ETHERCAT	72
TECHNICAL SPECIFICATIONS	72
PC/PLCSETUP	72
POSSIBLE COMMANDS TO BE SENT TO THE COMMAND REGISTER	74
<i>REAL CALIBRATION COMMANDS (WITH SAMPLE WEIGHTS)</i>	<i>75</i>
ETHERNET/IP	76
TECHNICAL SPECIFICATIONS	76
INSTRUMENT SETUP	76
PC/PLC SETUP	77
POSSIBLE COMMANDS TO BE SENT TO THE COMMAND REGISTER	79
<i>REAL CALIBRATION COMMANDS (WITH SAMPLE WEIGHTS)</i>	<i>80</i>
MODBUS/TCP	81
TECHNICAL SPECIFICATIONS	81
PC/PLCSETUP	81
IPADDRESSSETTING	81
POWERLINK	83
TECHNICAL SPECIFICATIONS	83
INSTRUMENT SETUP	83
PC/PLC SETUP	83
POSSIBLE COMMANDS TO BE SENT TO THE COMMAND REGISTER	85
<i>REAL CALIBRATION COMMANDS (WITH SAMPLE WEIGHTS)</i>	<i>86</i>
PROFIBUS-DP	87
TECHNICAL SPECIFICATIONS	87
INSTRUMENT SETUP	87
PC/PLC SETUP	87
POSSIBLE COMMANDS TO BE SENT TO THE COMMAND REGISTER	91
<i>REAL CALIBRATION COMMANDS (WITH SAMPLE WEIGHTS)</i>	<i>91</i>

PROFINET-IO	92
TECHNICAL SPECIFICATIONS	92
INSTRUMENT SETUP	92
PC/PLC SETUP	93
POSSIBLE COMMANDS TO BE SENT TO THE COMMAND REGISTER	95
<i>REAL CALIBRATION COMMANDS (WITH SAMPLE WEIGHTS)</i>	<i>96</i>
SERCOSIII	97
TECHNICAL SPECIFICATIONS	97
INSTRUMENT SETUP	97
PC/PLC SETUP	97
POSSIBLE COMMANDS TO BE SENT TO THE COMMAND REGISTER	99
<i>REAL CALIBRATION COMMANDS (WITH SAMPLE WEIGHTS)</i>	<i>100</i>
RESERVED FOR THE INSTALLER	101
MENU LOCKING	101
MENU UNLOCKING	101
TEMPORARY MENU UNLOCKING	101
DATA DELETION AND PROGRAM SELECTION	101
KEYPAD OR DISPLAY LOCKING	102
WARRANTY	103

USER WARNINGS

RECOMMENDATIONS FOR THE PROPER USE OF WEIGHING INSTRUMENT

- Keep away from heat sources and direct sunlight
- Do not wash with water jets
- Do not dip in water
- Do not spill liquid on the instrument
- Do not use solvents to clean the instrument
- Do not install in areas subject to explosion hazard
- If the working temperature reaches the permitted limits, it is advisable to distance the instrument to ensure adequate air flow and avoid malfunctions (Example: sudden shutdowns or disconnections)

RECOMMENDATIONS FOR INSTRUMENT INSTALLATION

The terminals to be connected to ground as indicated in the instrument's wiring diagram, must have the same potential as the weighed structure (same earthing pit or earthing system). If you are unable to ensure this condition, connect a grounding wire from the terminals of the instrument (including the terminal - SUPPLY) to the weighed structure.

The cell cable should be individually led to its panel input should not share a conduit with other cables, connect it directly to the instrument terminal strip without breaking its route with support terminal strips. Use "RC" filters on the instrument-driven solenoid valve and remote control switch coils. Avoid inverters in the instrument panel. If inevitable, use special filters for the inverters and separate them with sheet metal partitions. The panel installer must provide electric protections for the instruments (fuses, door lock switch etc.). It is advisable to leave the equipment always switched on to prevent the formation of condensation.

MAXIMUM CABLE LENGTHS

- RS485: 1000 meters with AWG24, shielded and twisted cables
- Analog current output: up to 500 meters with 0.5 mm² cable
- Analog voltage output: up to 300 meters with 0.5 mm² cable

RECOMMENDATIONS FOR LOAD CELL INSTALLATION

INSTALLING LOAD CELLS: the load cells must be placed on rigid, stable in-line structures. It is important to use the mounting modules for load cells to compensate for misalignment of the support surfaces.

CONNECTING SEVERAL CELLS IN PARALLEL: connect several cells in parallel by using a watertight junction box and terminal box if necessary. The cell connection extension cables must be shielded, led individually into their piping or conduit and laid as far as possible from the power cables (in case of 4-wire connections, use cables with 4x1 mm² minimum cross-section).

PROTECTION OF THE CELL CABLE: use water-proof sheaths and joints in order to protect the cables of the cells.

MECHANICAL RESTRAINTS (pipes, etc.): when pipes are present, we recommend the use of hoses and flexible couplings with open mouthpieces and rubber protection. In case of hard pipes, place the pipe support or anchor bracket as far as possible from the weighed structure (at a distance at least 40 times the diameter of the pipe).

WELDING: avoid welding with the load cells already installed. If this cannot be avoided, place the welder ground clamp close to the required welding point to prevent sending current through the load cell body.

WINDY CONDITIONS -KNOCKS- VIBRATIONS: the use of weigh modules is strongly recommended for all load cells to compensate for misalignment of the support surfaces. The system designer must ensure that the plant is protected against lateral shifting and tipping relating to: shocks and vibration, windy conditions, seismic activity in the installation setting and stability of the support structure.

GROUNDING THE WEIGHED STRUCTURE: by means of a copper wire with suitable cross-section, connect the cell upper support plate with the lower support plate, then connect all the lower plates to a single grounding system. Electrostatic charges accumulated because of the product rubbing against the pipes and the weighed container walls are discharged to the ground without going through or damaging the load cells. Failure to implement a proper grounding system may not affect the operation of the weighing system, however, this does not rule out the possibility that the cells and connected instrument may be damaged. It is not recommended to achieve grounding continuity through metal parts contained in the weighed structure.

FAILURE TO FOLLOW THE INSTALLATION RECOMMENDATIONS WILL BE CONSIDERED A MISUSE OF THE EQUIPMENT

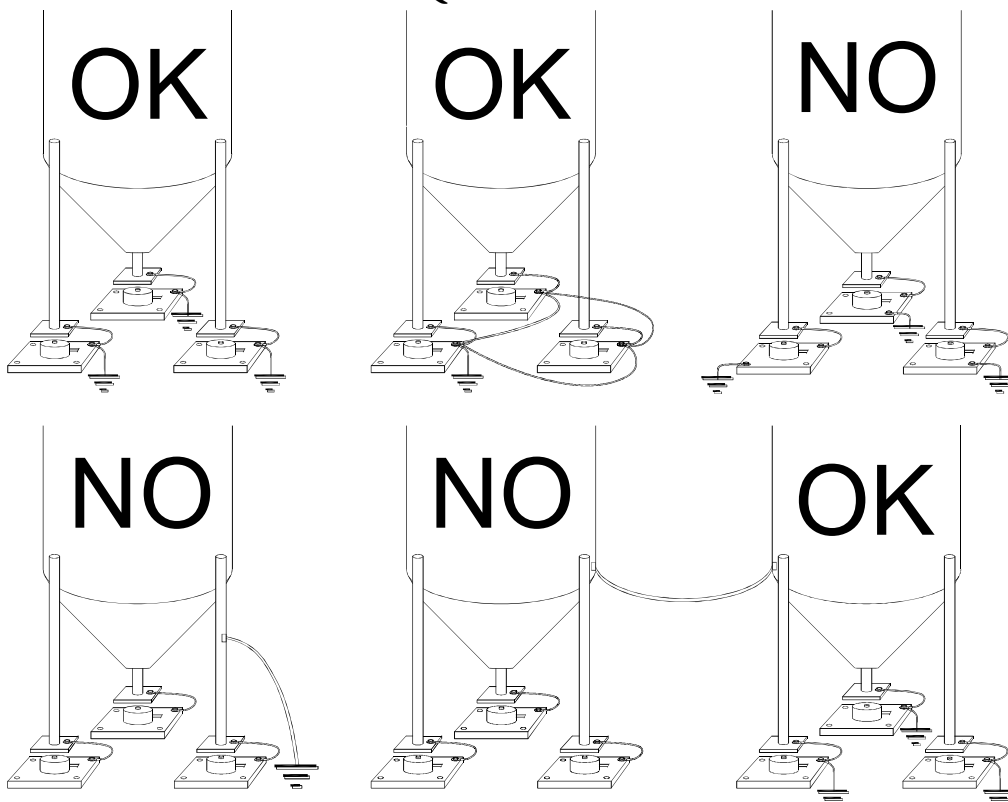

LOAD CELL INPUT TEST (QUICK ACCESS)

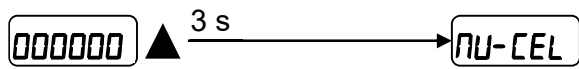

From the weight display, press  for 3 seconds: the display shows the response signal of the load cells expressed in mV with four decimals. Example: a load cell with 2.000 mV/V sensitivity provides a response signal between 0 and 10 mV.

LOAD CELL TESTING

Load cell resistance measurement (use a digital multimeter):

- Turn off the instrument.
- Disconnect the load cells from the instrument and make sure that there is no moisture in the load cell junction box caused by condensation or water infiltration. If so, drain the system or replace it if necessary.
- The value between the positive signal wire and the negative signal wire must be equal or similar to the one indicated in the load cell data sheet (output resistance).
- The value between the positive excitation wire and the negative excitation wire must be equal or similar to the one indicated in the load cell data sheet (input resistance).
- The insulation value between the shield and any other cell wire and between any other cell wire and the body of the load cell must be higher than 20 Mohm.

Load cell voltage measurement (use a digital multimeter):

- Turn on the instrument.
- Remove the load cell to be tested from beneath the container or lift the container support.
- Make sure that the two excitation wires from the load cell that are connected to the instrument (or amplifier) read 5 VDC \pm 3%.
- Measure the response signal between the positive and the negative signal wires by directly connecting them to the multimeter, and make sure that it reads between 0 and 0.5 mV.
- Apply load to the load cell and make sure that there is a signal increment.

IF ONE OF THE ABOVE CONDITIONS IS NOT MET, PLEASE CONTACT TECHNICAL SUPPORT.

MAIN INSTRUMENT SPECIFICATIONS

The INF1 is a weight transmitter with a 6-wire load cell input, suitable for assembly on back panel fitted Omega/DIN rail.

Dimensions: 25x115x120 mm. Six-digit semi-alphanumeric display, 8 mm height, 7 segment. Four-key keyboard.

RS485 serial port for connection to: PC/PLC up to 32 instruments (max 99 with line repeaters) by ASCII or ModBus R.T.U. protocol, remote display.

Optional: integrated CANopen, DeviceNet, CC-Link, PROFIBUS DP, Modbus/TCP, Ethernet TCP/IP, Ethernet/IP, PROFINET IO, EtherCAT, POWERLINK, SERCOS III output.

Optoisolated 16 bit analog output (tension or current).

TECHNICAL SPECIFICATIONS

POWER SUPPLY & CONSUMPTION	12/24 VDC $\pm 10\%$; 5 W
No. OF LOAD CELLS IN PARALLEL & SUPPLY	max 8 (350 ohm); 5 VDC / 120 mA
LINEARITY	< 0.01% F.S.
ANALOG OUTPUT LINEARITY	< 0.01% F.S.
THERMAL DRIFT	< 0.0005% F.S./ $^{\circ}\text{C}$
ANALOG OUTPUT THERMAL DRIFT	< 0.003 % F.S./ $^{\circ}\text{C}$
A/D CONVERTER	24 bit (16000000 points)
DIVISIONS (with measurement range ± 10 mV = sens. 2 mV/V)	± 999999
MEASUREMENT RANGE	± 39 mV
MAX SENSITIVITY OF USABLE LOAD CELLS	± 7 mV/V
MAX CONVERSIONS PER SECOND	300 conversions/second
DISPLAY RANGE	± 999999
NO. OF DECIMALS / DISPLAY INCREMENTS	0 - 4 / x 1 x 2 x 5 x 10 x 20 x 50 x 100
DIGITAL FILTER / READINGS PER SECOND	10 levels / 5 - 300 Hz
3 RELAY OUTPUTS	max 115 VAC; 150 mA
2 DIGITAL INPUTS	optoisolated 5 - 24 VDC PNP
SERIAL PORTS	RS485
BAUD RATE	2400, 4800, 9600, 19200, 38400, 115200
HUMIDITY (non condensing)	85%
STORAGE TEMPERATURE	-30 $^{\circ}\text{C}$ +80 $^{\circ}\text{C}$
WORKING TEMPERATURE	-20 $^{\circ}\text{C}$ +60 $^{\circ}\text{C}$
OPTOISOLATED ANALOG OUTPUT 16 bit - 65535 divisions	0-20 mA; 4-20 mA (max 300 ohm); 0-10 V; 0-5 V, ± 10 V; ± 5 V (min 10 kohm)

	RELAY OUTPUTS	max 30 VAC, 60 VDC; 150 mA
	Equipment to be powered by 12-24 VDC LPS or Class 2 power source.	

ELECTRICAL CONNECTIONS

BASIC INFORMATION

- It is recommended that the power supply negative pole be grounded.
- It is possible to supply up to 8 350 ohm load cells, or 16 700 ohm load cells.
- For 4-wire load cells, make a jumper between EX- and REF- and between EX+ and REF+.
- Connect terminal "- SUPPLY" to the RS485 common of the connected instruments in the event that these receive alternating current input or that they have an optically isolated RS485.
- In case of an RS485 network with several devices, it is recommended to activate the 120 ohm termination resistance on the two devices located at the ends of the network. This is described in the **RS485 SERIAL COMMUNICATION** section.

WIRING DIAGRAM

INF1 - INF1485 - INF1PROFI

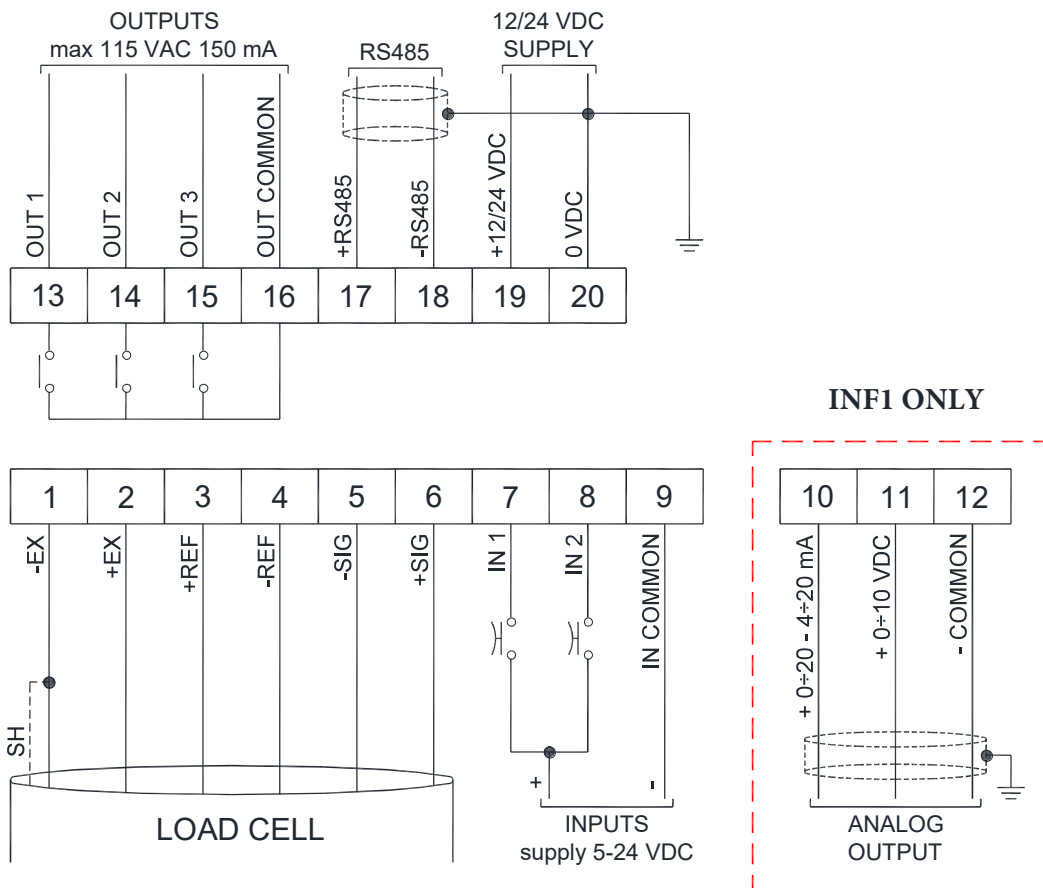

3 outputs: controlled by setpoint values or by remote device via protocol.

2 inputs (default: input 1= SEMI-AUTOMATIC ZERO; input 2= NET/GROSS): settable to have the following functions: SEMI-AUTOMATIC ZERO, NET/GROSS, PEAK or REMOTE CONTROL (see **INPUT AND OUPUT CONFIGURATION**).

TERMINALS LEGEND

1	-LOAD CELL EXCITATION (-EX)	11	+ANALOG OUTPUT 0-10 V
2	+LOAD CELL EXCITATION (+EX)	12	-ANALOG OUTPUT COMMON
3	+LOAD CELL REF/SENSE	13	OUTPUT No. 1
4	-LOAD CELL REF/SENSE	14	OUTPUT No. 2
5	-LOAD CELL SIGNAL	15	OUTPUT No. 3
6	+LOAD CELL SIGNAL	16	OUTPUT COMMON
7	INPUT No. 1 (+VDC min 5 V max 24 V)	17	RS485: +
8	INPUT No. 2 (+VDC min 5 V max 24 V)	18	RS485: -
9	INPUT COMMON (-VDC 0 V)	19	+SUPPLY (12/24 VDC)
10	+ANALOG OUTPUT 0-20 or 4-20 mA	20	-SUPPLY(12/24 VDC) RS485: SHIELD, GND

INF1 (other models)

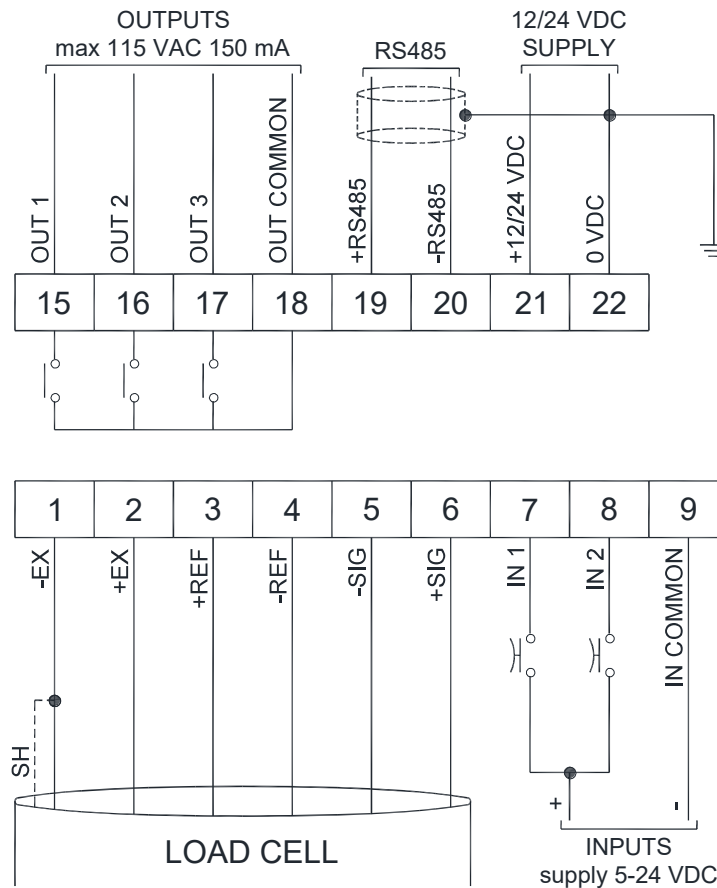

3 outputs: controlled by setpoint values or by remote device via protocol.





2 inputs (default: input 1= SEMI-AUTOMATIC ZERO; input 2= NET/GROSS): settable to have the following functions: SEMI-AUTOMATIC ZERO, NET/GROSS, PEAK or REMOTE CONTROL (see **INPUT AND OUTPUT CONFIGURATION**).

TERMINALS LEGEND

1	-LOAD CELL EXCITATION (-EX)	15	OUTPUT No. 1
2	+LOAD CELL EXCITATION (+EX)	16	OUTPUT No. 2
3	+LOAD CELL REF/SENSE	17	OUTPUT No. 3
4	-LOAD CELL REF/SENSE	18	OUTPUT COMMON
5	-LOAD CELL SIGNAL	19	RS485: +
6	+LOAD CELL SIGNAL	20	RS485: -
7	INPUT No. 1 (+VDC min 5 V max 24 V)	21	+SUPPLY (12/24 VDC)
8	INPUT No. 2 (+VDC min 5 V max 24 V)	22	-SUPPLY (12/24 VDC) RS485: SHIELD,GND
9	INPUT COMMON (-VDC 0 V)		

LED AND KEYS FUNCTIONS

LED	Main function	Secondary function
NET	net weight (semi-automatic tare or preset tare)	LED lit: output 3 closed
→0←	zero (deviation from zero not more than ±0.25 divisions)	LED lit: output 2 closed
▾	stability	LED lit: output 1 closed
kg	unit of measure: kg	
g	unit of measure: g	LED lit: input 2 closed
L	unit of measure other than kg or g	LED lit: input 1 closed

To activate the secondary LED function, during weight display press and hold down the keys  and  (press  immediately followed by ).

KEY	Short press	Long press (3 s)	Into menus
✕	Semi-automatic zero	Tare resetting	Cancel or return to previous menu
◀	Gross → Net	Net → Gross	Select figure to be modified or go to previous menu item.
▲		mV load cell test	Modify selected figure or go to next menu item
↵	Setting setpoint and hysteresis		Confirm or enter in submenu
↵+✕	Setting general parameters (press ↵ immediately followed by ✕)		
↵+◀	Setting preset tare (press ↵ immediately followed by ▶)		



Into menu LEDs light up in sequence to indicate that it is not displaying a weight.

MENU MAP

Into menu changes are applied right after pressing the  key (no further confirmation is required).

SETPOINT



SYSTEM PARAMETERS

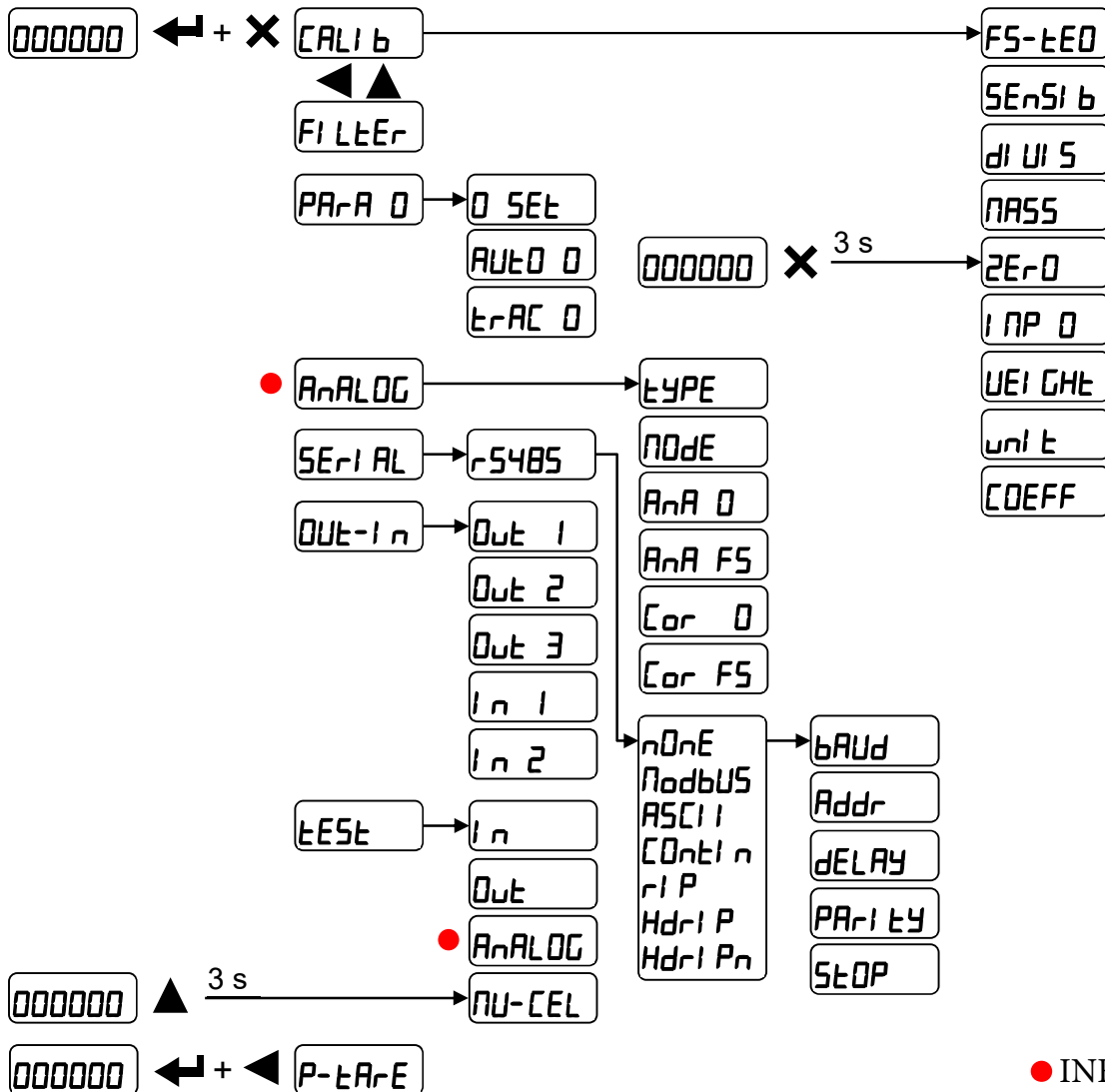

INSTRUMENT COMMISSIONING



Upon switch-on, the display shows in sequence:





- `111111` → `999999` (ONLY in case of approved program);
- instrument model (e.g.: `tLb`);
- `SU` followed by the software code (e.g.: `SU 5`);
- program type: `bASE`(base);
- `r` followed by the software version (e.g.: `r 1.13.00`);
- `HU` followed by the hardware code (e.g.: `HU 104`);
- serial number (e.g.: `1005 15`);

Check that the display shows the weight and that when loading the load cells, there is an increase in weight. If there is not, check and verify the connections and correct positioning of the load cells.









- **If the instrument has already been theoretical CALIBRATED** (plant system identification tag present on the instrument and on the cover: load cell's rated data already entered)
 - Reset to zero (see **TARE WEIGHT ZERO SETTING**).
 - Check the calibration with sample weights and correct the indicated weight if necessary (see **REAL CALIBRATION (WITH SAMPLE WEIGHTS)**).
- **If the instrument HAS NOT BEEN CALIBRATED** (missing plant system identification tag) proceed with calibration:
 - If load cells data is unknown, follow the procedure in the **REAL CALIBRATION (WITH SAMPLE WEIGHTS)** section.
 - Enter the rated data of the load cells following the procedure given in the **THEORETICAL CALIBRATION** section.
 - Reset to zero (see **TARE WEIGHT ZERO SETTING**).
 - Check the calibration with sample weights and correct the indicated weight if necessary (see **REAL CALIBRATION (WITH SAMPLE WEIGHTS)**).
- If you use the analog output, set the desired analog output type and the full scale value (see **ANALOG OUTPUT**).
- If you use serial communication, set the related parameters (see **SERIAL COMMUNICATION SETTING**).
- If setpoints are used, set the required weight values and the relevant parameters (see **SETPOINT PROGRAMMING** and **INPUT AND OUTPUT CONFIGURATION**).

PROGRAMMING OF SYSTEM PARAMETERS

From the weight display, press simultaneously keys  and  to access the parameter setting.

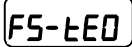
- : to enter a menu/confirm the data entry.
- : to modify the displayed figure or menu item.
- : to select a new figure or modify the displayed menu item.
- : to cancel and return to the previous menu.

THEORETICAL CALIBRATION

  +        

This function allows the load cell rated values to be set.

To perform the theoretical calibration set the following parameters in sequence:

- **FS-tED**(default: **dEN0**): the **system full scale** is given by one cell capacity multiplied by the number of cells used. Example: 4 cells of 1000 kg → FULL SCALE = 1,000 x 4 = 4,000. The instrument is supplied with a theoretical full scale value **dEN0** corresponding to 10,000. To restore factory values, set 0 as full scale.
- **SEnSi b**: (default: 2.00000 mV/V): **sensitivity** is a load cell rated parameter expressed in mV/V. Set the average sensitivity value indicated on the load cells. It's possible to set a value between 0.50000 and 7.00000 mV/V. Example of 4-cell system with sensitivity: 2.00100, 2.00150, 2.00200, 2.00250; enter 2.00175, calculated as $(2.00100 + 2.00150 + 2.00200 + 2.00250) / 4$.
- **dI UI S**: the **division** (resolution) is the minimum weight increment value which can be displayed. It is automatically calculated by the system according to the performed calibration, so that it is equal to 1/10000 of full scale. It can be changed and be variable between 0.0001 and 100 with x1 x2 x5 x10 increments.
 - By modifying the theoretical full scale, the sensitivity or the division, the real calibration is canceled and the theoretical calibration only is considered valid.
 - If the theoretical full scale and the recalculated full scale in real calibration (see **REAL CALIBRATION (WITH SAMPLE WEIGHTS)**) are equal, this means that the calibration currently in use is theoretical; if they are different, the calibration in use is the real calibration based on sample weights.
 - By modifying the theoretical full scale or the divisions, the system's parameters containing a weight value will be set to default values (setpoint, hysteresis, etc.).

MAXIMUM CAPACITY

000000 ← + ✕ CALI b ← FS-tEO ◀ ▲ MASS

MASS: maximum displayable weight (from 0 to max full scale; default: 0). When the weight exceeds this value by 9 divisions, the display shows -----. To disable this function, set 0.

TARE WEIGHT ZERO SETTING

000000 ← + ✕ CALI b ← FS-tEO ◀ ▲ ZErO

This menu may also be accessed directly from the weight display, holding down the ✕ key for 3 seconds.

Perform this procedure after having set the THEORETICAL CALIBRATION data.

Use this function to set to zero the weight of the empty system after commissioning and then later on to compensate zero variations due to the presence of product residues.

Procedure:

- Confirm the message **ZErO** by pressing ◀.
- The weight value to be set to zero is displayed. In this phase all of the LEDs are flashing.
- Confirming once again, the weight is set to zero (the value is stored to the permanent memory).
- Press ▲ to display the value of the total weight reset by the instrument, given by the sum of all of the previous zero settings.

ZERO VALUE MANUAL ENTRY

000000 ← + ✕ CALI b ← FS-tEO ◀ ▲ INP 0

WARNING: Perform this procedure only if it's not possible to reset weighted structure tare, for example because it contains product that cannot be unloaded. Set in this parameter the estimated zero value (from 0 to max 999999; default: 0).

REAL CALIBRATION (WITH SAMPLE WEIGHTS)



After having performed the THEORETICAL CALIBRATION and TARE WEIGHT ZERO SETTING, this function allows correct calibration to be done using sample weights of known value and if necessary, any deviations of the indicated value from the correct value to be corrected.

Load a sample weight onto the weighing system that is **at least 50%** of the maximum quantity to be weighed.

By confirming the message **UEI GHt** the flashing value of the weight currently on the system is displayed. In this phase all of the LEDs are off. Adjust the value on display by using the arrow keys if necessary. After confirming, the new set weight will appear with all the LEDs flashing. After an additional confirmation, the message **UEI GHt** will be restored and by repeatedly pressing the key **X** the weight will once again be displayed.

Example: for a system of maximum capacity 1,000 kg and 1 kg division, two sample weights are available, one of 500 kg and the other one of 300 kg. Load both weights onto the system and correct the indicated weight to 800. Now remove the 300 kg weight, the system must show 500, then remove the 500 kg weight too and the system must read zero. If this does not happen, it means that there is a mechanical problem affecting the system linearity.

WARNING: identify and correct any mechanical problems before repeating the procedure.

- If theoretical full scale and recalculated full scale in real calibration are equal, it means that the theoretical calibration is currently in use. Otherwise, the real calibration based on sample weights is in use.
- If the correction made changes the previous full scale for more than 20%, all the parameters with settable weight values are reset to default values.

LINEARISATION OPTION ON MAX 5 POINTS:

It is possible to perform a linearisation of the weight repeating the above-described procedure up to a maximum of five points, using five different sample weights. The procedure ends by pressing the **X button or after entering the fifth value;** at this point it will no longer be possible to change the calibration value, but only to perform a new real calibration. To perform a new calibration, return to the weight display and then re-enter the calibration menu.

By pressing **▲** after confirming the sample weight that has been set, the full scale appears recalculated according to the value of the maximum sample weight entered, with reference to the cell sensitivity set in the theoretical calibration (**SEnSi b**).

FILTER ON THE WEIGHT



Setting this parameter allows a stable weight display to be obtained.

To increase the effect (weight more stable) increase the value (from 0 to 9, default 4). As seen in the diagram:

- By confirming the **FILTER** message, the currently programmed filter value is displayed.
- By changing and confirming the value, the weight is displayed and it will be possible to experimentally verify its stability.
- If stability is not satisfactory, confirming brings back the message **FILTER** and the filter may be modified again until an optimum result is achieved.

The filter enables to stabilize a weight as long as its variations are smaller than the corresponding "response time". It is necessary to set this filter according to the type of application and to the full scale value set.

FILTER VALUE	Response times [ms]	Display and serial port refresh frequency [Hz]
0	12	300
1	150	100
2	260	50
3	425	25
4 (default)	850	12.5
5	1700	12.5
6	2500	12.5
7	4000	10
8	6000	10
9	7000	5

ANTI PEAK

When the weight is stable, the anti peak filter removes any sudden disturbances with a maximum duration of 1 second. Confirm the filter on the weight with and select one of the following options:

- **AntPON** : anti peak filter enabled (default).
- **AntPOF** : anti peak filter disabled.

ZERO PARAMETERS



RESETTABLE WEIGHT SETTING FOR SMALL WEIGHT CHANGES

0 SET (from 0 to max full scale; default: 300; considered decimals: 300 - 30.0 - 3.00 - 0.300): this parameter indicates the maximum weight value resettable by external contact, keypad or serial protocol.

AUTOMATIC ZERO SETTING AT POWER-ON

AUTO 0 (from 0 to max 20% of full scale; default: 0): if at switch-on the weight value is lower than the value set in this parameter and does not exceed the **0 SET** value, the weight is reset. To disable this function, set 0.

ZERO TRACKING

TRAC 0 (from 1 to 5, default: **nONE**): when the weight value is stable and after a second, it deviates from zero by a figure in divisions smaller or equal to the figure in divisions set in this parameter, the weight is set to zero. To disable this function, set **nONE**.

Example: if the parameter **DI UI 5** is set to 5 and **TRAC 0** is set to 2, the weight will be automatically set to zero for variations smaller than or equal to 10 (**DI UI 5** x **TRAC 0**).

SETTING UNITS OF MEASURE



These are the available units of measure:

HI LOG:	kilograms
G:	grams
t:	tons
Lb:	pounds*
nEUton:	newtons*
LI tErE:	liters*
bAr:	bars*
AtM:	atmospheres*
PI ECE:	pieces*
nEU-M:	newton meters*
HI LO-M:	kilogram meters*
OTHEr:	other generic units of measure not included in the list*

For units marked with * it is also possible to set the display coefficient (parameter **COEFF**, see the related section). To use **COEFF** is necessary to enable it, closing the **COEFF** input (see **INPUT AND OUTPUT CONFIGURATION**).

DISPLAY COEFFICIENT



By setting the coefficient **COEFF** the display is changed accordingly.

If one of the inputs is set to **COEFF** mode (see **INPUT AND OUTPUT CONFIGURATION**) when the input is closed the value will be displayed modified according to the **COEFF** coefficient, when the input is opened the standard weight display will be restored.

COEFF (max settable value: 99.9999; default: 1.0000): will have different meanings according to the value set in **unit**, i.e. the selected unit of measure. (see **SETTING UNITS OF MEASURE**).

If the unit of measure chosen is:

Lb: pounds, the value set in **COEFF** will be multiplied by the weight value currently displayed.

nEUton: newton, the value set in **COEFF** will be multiplied by the weight value currently displayed.

LitRE: liters, in **COEFF** set the specific weight in kg/l, assuming that the system is calibrated in kg.

bAr: bar, the value set in **COEFF** will be multiplied by the weight value currently displayed.

Atm: atmosphere, the value set in **COEFF** will be multiplied by the weight value currently displayed.

PIECE: pieces, in **COEFF** set the weight of one piece.

nEU-m: newton meters, the value set in **COEFF** will be multiplied by the weight value currently displayed.

kg-m: kilogram meters, the value set **COEFF** will be multiplied by the weight value currently displayed.

Other: generic unit of measure not included in the list, the value set in **COEFF** will be multiplied by the weight value currently displayed.

WARNING: All other settings (setpoint, hysteresis, calibration ...) are expressed in weight value. If you want to convert them to a new unit of measurement, perform one of the following procedures for changing the system calibration. The parameter **COEFF** must remain set to 1.0000.

THEORETICAL CALIBRATION'S CHANGE FOR OTHER UNITS OF MEASURE

Set in the parameter **F5-LED** the F.SCALE value divided by the conversion coefficient from kg to the new unit of measure.

Example: the 4 load cells of 1000 kg are placed under a scale for olive oil, which has a specific gravity of 0.916 kg/l. Setting the $F.SCALE = (4 \times 1000) / 0.916 = 4367$, the system works in liters of olive oil. Also, if you set the parameter **Unit = LitRE** (see **SETTING UNITS OF MEASURE**), the system will display the symbol "l" instead of "kg".

REAL CALIBRATION'S CHANGE FOR OTHER UNITS OF MEASURE

Load a known quantity of product liters on the scale (equal to at least 50% of the maximum amount that you must weigh) and enter the product loaded value in liters into the **UEI GHE** parameter. Also, if you set the parameter **Unit = LitRE** (see **SETTING UNITS OF MEASURE**), the system will display the symbol "l" instead of "kg".

INPUT AND OUTPUT CONFIGURATION

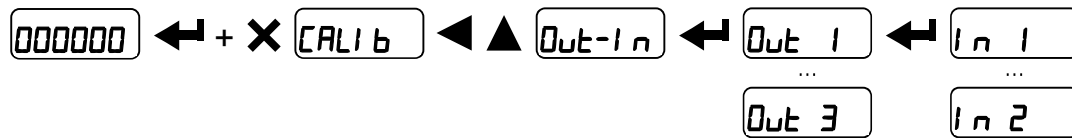

OUTPUTS

The outputs are set by default as follows: *OPE_n* / *SEt* / *GrOSS* / *POS_nEG* / *OFF*.

Possible operation modes:

- ***OPE_n* (normally open)**: the relay is de-energized and the contact is open when the weight is lower than the programmed setpoint value. It closes when the weight is higher than or equal to the programmed setpoint value.
- ***CLOSE* (normally closed)**: the relay is energized and the contact is closed when the weight is lower than the programmed setpoint value. It opens when the weight is higher than or equal to the programmed setpoint value.
- ***SEt***: the contact will switch on the basis of weight, according to setpoint (see **SETPOINT PROGRAMMING**).
- ***PLC***: the contact will not switch on the basis of weight, but is controlled by remote protocol commands.
- ***StAbLE***: relay switching occurs when the weight is stable.
- ***ALAR_n***: relay switching occurs when one of the following alarms is triggered: *ErCEL*, *Er DL*, *Er Ad*, -----, *Er DF*; the operation mode is forced to ***CLOSE*** (normally closed).

If the operation mode ***SEt*** is selected, the following options are also active:

- ***GrOSS***: the contact will switch on the basis of gross weight.
- ***nEt***: the contact will switch on the basis of net weight (If the net function is not active, the contact will switch on the basis of gross weight).
- ***POS_nEG***: relay switching occurs for both positive and negative weight values.
- ***POS***: relay switching occurs for positive weight values only.
- ***nEG***: relay switching occurs for negative weight values only.

By confirming with the setpoint operation can be set to the value 0:

- ***OFF***: relay switching will not occur if the setpoint value is 0.
- ***On***:
 - setpoint = 0 and switching = ***POS_nEG***: relay switching occurs when the weight is 0. The relay will switch again when the weight is other than zero, taking hysteresis into account (both for positive and for negative weights).
 - setpoint = 0 and switching = ***POS***: relay switching occurs for a weight higher than or equal to 0, the relay will switch again for values below 0, taking hysteresis into account.
 - setpoint = 0 and switching = ***nEG***: relay switching occurs for a weight lower than or equal to 0, the relay will switch again for values above 0, taking hysteresis into account.

INPUTS



Default: input 1 = **2E-0** input 2 = **nE-L0**

Possible operation modes:

- **nE-L0** (NET/GROSS): by closing this input for no more than one second, it's making an operation of SEMI-AUTOMATIC TARE and the display will show the net weight. To display the gross weight again, hold the NET/GROSS input closed for 3 seconds.
- **2E-0**: by closing the input for no more than one second, the weight is set to zero (see **WEIGHT ZERO-SETTING FOR SMALL VARIATIONS (SEMI-AUTOMATIC ZERO)**).
- **PEAH** : keeping the input closed, the maximum weight value reached remains on display. Opening the input the current weight is displayed.
- **PLC**: closes the input, no operation is performed. The input status may however be read remotely by way of the communication protocol.
- **Cont n** : closing the input for a maximum of one second, the weight is transmitted over the serial connection according to the fast continuous transmission protocol only once (**only if Cont n is set in the item SERIAL**).
- **COEFF**: when the input is closed, the weight is displayed based on the set coefficient (see setting of the units of measure and coefficient), otherwise the weight is displayed.

SEMI-AUTOMATIC TARE (NET/GROSS)

WARNING: THE SEMI-AUTOMATIC TARE OPERATION IS LOST UPON INSTRUMENT POWER-OFF.

To perform a net operation (SEMI-AUTOMATIC TARE), close the NET/GROSS input or press the  key for less than 3 seconds. The instrument displays the net weight (just set to zero) and the NET symbol lights up. To display the gross weight again, keep the NET/GROSS input closed or press  for 3 seconds.

This operation can be repeated many times by the operator to allow the loading of several products.

Example:

Put the box on the scale, the display shows the box weight; press  , the display shows the net weight to zero; introduce the product in the box, the display shows the product weight. This operation can be repeated several times.



While the net weight is displayed, keep  pressed to display the preset tare. When the key is released the net weight will be displayed again.

The semi-automatic tare operation is not allowed if the gross weight is zero.

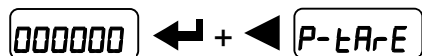
PRESET TARE (SUBTRACTIVE TARE DEVICE)



It is possible to manually set a preset tare value to be subtracted from the display value provided that the $P-tArE \leq \text{max capacity condition}$ is verified.



By default the instrument shows the last programmed preset tare value: to apply it, press  and then . After setting the tare value, go back to the weight display. The display shows the net weight (subtracting the preset tare value) and the NET LED lights up to show that a tare has been entered. To delete a preset tare and return to gross weight display, hold down  for about 3 seconds or keep the NET/GROSS input (if any) closed for the same length of time (3 seconds). The preset tare value is set to zero. The NET LED is turned off when the gross weight is displayed once again.

While the net weight is displayed, keep  pressed to display the gross weight. When the key is released the net weight will be displayed again.

- IF A SEMI-AUTOMATIC TARE (NET) IS ENTERED, IT IS NOT POSSIBLE TO ACCESS THE ENTER PRESET TARE FUNCTION.
- IF A PRESET TARE IS ENTERED, IT'S STILL POSSIBLE TO ACCESS THE SEMI-AUTOMATIC TARE (NET) FUNCTION. THE TWO DIFFERENT TYPES OF TARE ARE ADDED.

ALL THE SEMI-AUTOMATIC TARE (NET) AND PRESET TARE FUNCTIONS WILL BE LOST WHEN THE INSTRUMENT IS TURNED OFF.

SEMI-AUTOMATIC ZERO (ZERO-SETTING FOR SMALL VARIATIONS)

By closing the SEMI-AUTOMATIC ZERO input, the weight is set to zero. Alternatively, by pressing the  key, the **SEtErP** message is displayed for 3 seconds, by pressing  the weight is set to zero.

This function is only allowed if the weight is lower than the **D SEt** value (see **RESETTABLE WEIGHT SETTING FOR SMALL WEIGHT CHANGES**), otherwise the alarm **t-----** appears and the weight is not set to zero.

WARNING: The zero-setting is lost upon instrument power-off.

PEAK

By keeping the PEAK input closed the maximum weight value reached remains displayed. By opening the input the current weight is displayed.

If you wish to use this input to view a sudden variation peak, set the FILTER ON THE WEIGHT to 0.

ANALOG OUTPUT

000000 ← + X CALIB ← ▲ ANALOG

- **TYPE**: Selects the analog output type (4-20 mA, 0-20 mA, 0-10 V, 0-5 V, ± 10 V, ± 5 V; default: 4-20 mA).

For the output ± 10 V and ± 5 V a soldered jumper must be closed (the operation makes the other analog outputs unusable):

- open the instrument.
- locate in the printed circuit board the soldered jumper highlighted in the picture below:

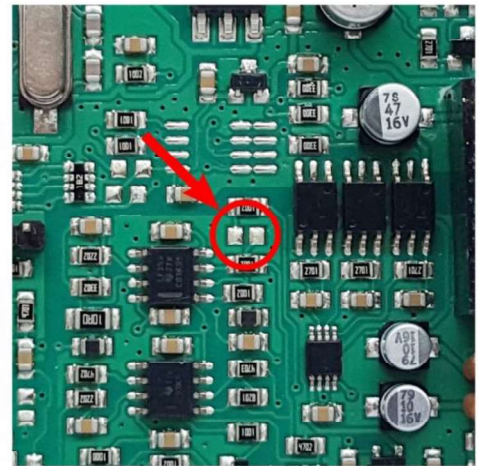
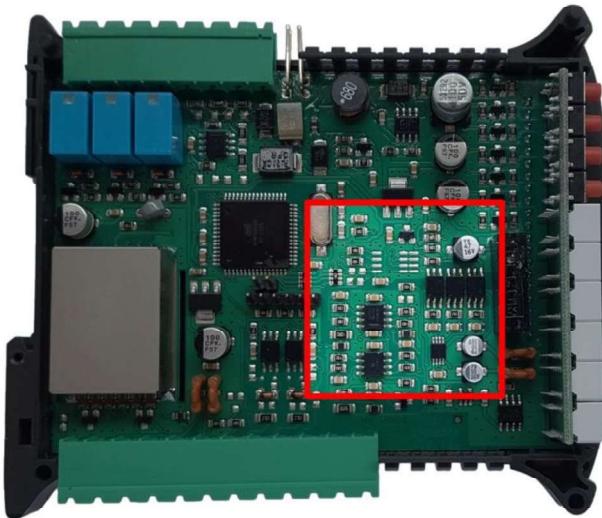

- close the jumper shorting the pads with a drop of tin.
- **MODE**: choice of a weight followed by the analog output: gross (**GROSS**) or net (**NET**). If the net function is not active, the analog output varies according to gross weight.
- **ANALOG**: set the weight value for which you wish to obtain the minimum analog output value.

Only set a value different from zero if you wish to limit the analog output range. If for instance you require a 4 mA signal at a full scale value of 10,000 kg and a 20 mA signal at 5,000 kg, use 5,000 kg instead of zero.

- ***AnA F5***: set the weight value at which you want to obtain the maximum analog output value. It must correspond to the value set in the PLC program (default: calibration full scale). **Example:** if I am using a 4-20 mA output and in the PLC program I want to have 20 mA = 8,000 kg, I will set the parameter to 8,000.
- ***COr 0***: **analog output correction to zero:** if necessary adjust the analog output, allowing the PLC to indicate 0. The "-" can be set for the last digit on the left. **Example:** If I use a 4-20 mA output and the minimum analog setting on the PLC or tester reads 4.1 mA, I must set the parameter to 3.9 to obtain 4.0 on the PLC or tester.
- ***COr F5***: **correction of analog output to full scale:** If necessary permit the modification of the analog output, by allowing the PLC to indicate the value set in the parameter ***AnA F5***. **Example:** If I am using a 4-20 mA output with the analog set to full scale and the PLC or tester reads 19.9 mA, I must set the parameter to 20.1 to get 20.0 on the PLC or tester.

Minimum and maximum values which can be set for zero and full scale corrections:

ANALOG OUTPUT TYPE	Minimum	Maximum
0-10 V	-0.150	10.200
0-5 V	-0.150	5.500
±10 V	-10.300	10.200
±5 V	-5.500	5.500
0-20 mA	-0.200	22.000
4-20 mA	-0.200	22.000

NOTE: the analog output may also be used in the opposite manner, i.e. the weight setting that corresponds to the analog zero (***AnA 0***) may be greater than the weight set for the analog full scale (***AnA F5***). The analog output will increase towards full scale as the weight decreases, the analog output will decrease as the weight increases.

For example:

AnA 0 = 10000 ***AnA F5*** = 0 analog output 0÷10 V

Weight = 0 kg analog output = 10 V

Weight = 5000 kg analog output = 5 V

Weight = 10000 kg analog output = 0 V

All analog outputs of the instrument are ACTIVE and SINGLE ENDED type, therefore they can be connected only to PASSIVE receiver devices. The minimum load allowed for voltage outputs is 10 kohm, the maximum load allowed for current outputs is 300 ohm.

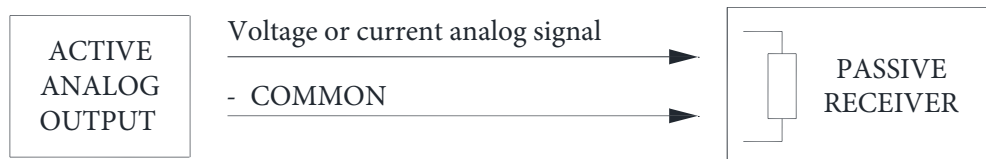

SERIAL COMMUNICATION SETTING



- **nOnE**: it disables any type of communication (default).
- **ModBUS**: MODBUS-RTU protocol; possible addresses: from 1 to 99 (see **Communication Protocols**).
- **ASCII**: ASCII bidirectional protocol; possible addresses: from 1 to 99 (see **Communication Protocols**).
 - **Mod Ad**
- **Cont n**: continuous weight transmission protocol (see **Communication Protocols**), at the frequency set **HErt2** in item (from 10 to 300).
 - **Mod t** (set: **PARITY** = **nOnE**, **STOP** = 1).
 - **Mod Ad** (set: **PARITY** = **nOnE**, **STOP** = 1).
 - **BAUD**: transmission speed (2400, 4800, 9600, 19200, 38400, 115200; default: 9600).
 - **Addr**: instrument address (from 1 to 99; default: 1).
 - **HErt2**: maximum transmission frequency (10 - 20 - 30 - 40 - 50 - 60 - 70 - 80 - 100 - 200 - 300; default: 10); to be set when the **Cont n** transmission protocol is selected. Maximum setting frequency (**HErt2**):
 - 20 Hz with minimum baud rate 2400 baud.
 - 40 Hz with minimum baud rate 4800 baud.
 - 80 Hz with minimum baud rate 9600 baud.
 - 100 Hz with minimum baud rate 19200 baud.
 - 200 Hz with minimum baud rate 38400 baud.
 - 300 Hz with minimum baud rate 38400 baud.
 - **dELAY**: delay in milliseconds which elapses before the instrument replies (from 0 to 200 ms; default: 0).
 - **PARITY**:
 - **nOnE**: no parity (default).
 - **EVEN**: even parity.
 - **Odd**: odd parity.
 - **STOP**: stop bit (1 - 2; default: 1).

RS485 SERIAL COMMUNICATION

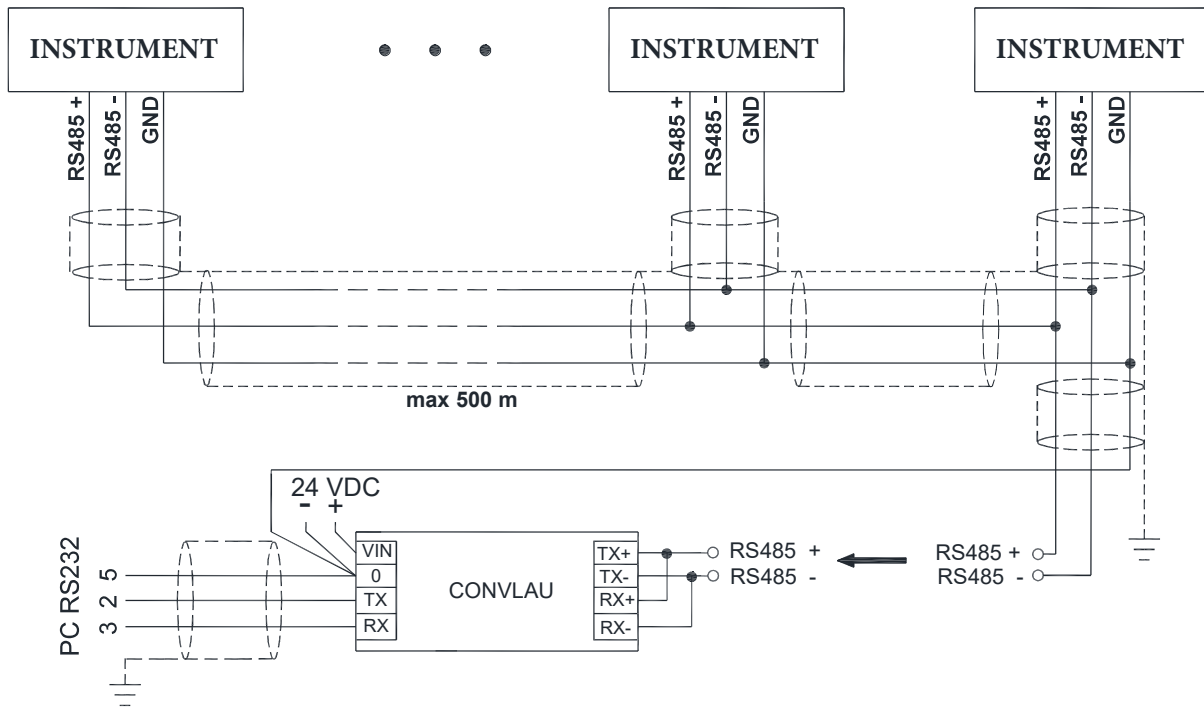

If the RS485 network exceeds 100 meters in length or a baud-rate over 9600 is used, two terminating resistors are needed at the ends of the network: close the two jumpers indicated in the picture on the furthest instruments. If there are different instruments or converters, refer to the specific manuals to determine whether it is necessary to connect the above-mentioned resistors.



DIRECT CONNECTION BETWEEN RS485 AND RS232 WITHOUT CONVERTER

Since a two-wire RS485 output may be used directly on the RS-232 input of a PC or remote display, it is possible to implement instrument connection to an RS-232 port in the following manner:

INSTRUMENT		RS232
RS485 -	→	RXD
RS485 +	→	GND



This type of connection allows A SINGLE instrument to be used in a ONE WAY mode.





TEST



- **Input Test:**
 - IN:** ensure that for each open input **0** is displayed, **1** is displayed when the input is closed.
- **Output Test:**
 - OUT:** setting **0** ensure that the corresponding output opens. Setting **1** ensure that the corresponding output closes.
- **Analog Output Option Test:**
 - ANALOG:** allows the analog signal to range between the minimum and the maximum values starting from the minimum.
 - mA:** current output test.
 - VOLT:** voltage output test.
- **Millivolt Test:**
 - mV-CEL:** displays the response signal of each load cell expressed in mV with four decimals.

SETPOINT PROGRAMMING

From the weight display, press  to access the setpoint setting.

- : to enter a menu/confirm the data entry.
- : to modify the displayed figure or menu item.
- : to select a new figure or modify the displayed menu
- : item. to cancel and return to the previous menu.

   ...    ... 

- **SEt** (from 0 to max full scale; default: 0): Setpoint; relay switching occurs when the weight exceeds the value set in this parameter. The type of switching is settable (see **INPUT AND OUTPUT CONFIGURATION**).
- **HYSEt** (from 0 to max full scale; default: 0): Hysteresis, is the value to be subtracted from the setpoint to obtain contact switching for decreasing weight. For example with a setpoint at 100 and hysteresis at 10, the switching occurs at 90 for decreasing weight.

These values are set to zero if the calibration is changed significantly (see **THEORETICAL CALIBRATION** and **REAL CALIBRATION (WITH SAMPLE WEIGHTS)**).

ALARMS

- ErCEL** : The load cell is not connected or is incorrectly connected. The load cell signal exceeds 39 mV. The conversion electronics (AD converter) is malfunctioning. The load cell is a 4-wire configuration and there are no jumpers between EX- and REF- and between EX+ and REF+. The references are not connected or incorrectly connected.
- Er OL** : The weight display exceeds 110% of the full scale.
- Er Ad** : Internal instrument converter failure. Check load cell connections, if necessary contact technical support.
- : The weight exceeds the maximum capacity by 9 divisions.
- Er OF** : Maximum displayable value exceeded (value higher than 999999 or lower than -999999).
- ε-----** : Weight too high, zero setting not possible.
- PAH-PU** : This message appears in the sample weight setting and in real calibration, after the fifth sample weight value has been entered.
- Error** : The value set for the parameter is beyond the permitted values. Press **✕** to quit the setting mode, leaving the previous value unchanged. **Examples:** A number of decimals are selected for full scale, that exceed the instruments display potential. The value is above the maximum setting value. The weight value set in sample weight verification does not match the detected mV increase. The analog output correction goes beyond the permitted limits.
- blOC** : lock active on menu item, keypad or display.
- nOdl SP** : it's not possible to display the number properly because it is greater than 999999 or less than -999999.

Serial protocol alarms:

	<i>ErCEL</i>	<i>Er OL</i>	<i>Er Ad</i>	-----	<i>Er OF</i>	ε-----
MODE						
Bit LSB	76543210	76543210	76543210	76543210	76543210	The response to the zero command is a "value not valid" error (error code 3)
Status Register MODBUS RTU	xxxxxxx1	xxxx1xxx	xxxxxx1x	xxxxx1xx	On gross: xxx1xxxx On net: xx1xxxxx	
ASCII	_O-F_	_O-L_	_O-F_	_O-L_	_O-F_	&aa#CR
RIP *	_O-F_	_O-L_	_O-F_	_O-L_	_O-F_	_O-F_
HDRIP-N	_ERCEL	_ER_OL	_ER_AD	#####	_ER_OF	O_SET
CONTIN	_ERCEL	_ER_OL	_ER_AD	^^^^^^	_ER_OF	O_SET

* For RIP remote displays, if the message exceeds 5 digits the display reads -----.

With an alarm, the relays open and the analog outputs go to the lowest possible value according to the following table:

RANGE	0-20 mA	4-20 mA	0-5 V	0-10 V	±10 V	±5 V
Output value	-0.2 mA	3.5 mA	-0.5 V	-0.5 V	0 V	0 V

COMMUNICATION PROTOCOLS

CONTINUOUS FAST WEIGHT TRANSMISSION PROTOCOL

This protocol allows the continuous transmission of weight at high update frequencies. Up to 300 strings per second are transmitted with a minimum transmission rate of 38400 baud. Following communication modes are available (see **SERIAL COMMUNICATION SETTINGS**):

- **Mod t**: communication compatible with TX RS485 instruments
- **Mod td**: communication compatible with TD RS485 instruments

If **Mod t** is set, the following string is transmitted to PC/PLC:

xxxxxxCRLF

where: **xxxxxx**.....6 characters of gross weight (48 – 57 ASCII)

CR.....1 character return to the start (13 ASCII)

LF.....1 character on new line (10 ASCII)

In case of negative weight, the first character from the left of the weight characters takes on the value “-” (minus sign - ASCII 45).

In case of error or alarm, the 6 characters of the weight are substituted by the messages found in the table of the ALARMS section.

If **Mod td** is set, the following string is transmitted to PC/PLC:

&TzzzzzzPzzzzzz\ckckCR

where: **&**.....1 initial string character (38 ASCII)

T.....1 character of gross weight identification

P.....1 character of gross weight identification

zzzzzz.....6 characters of gross weight (48 ÷ 57 ASCII)

****.....1 character of separation (92 ASCII)

ckck.....2 ASCII control characters or calculated considering the characters included between “&” and “\” excluded. The control value is obtained executing the XOR operation (exclusive OR) for the 8 bit ASCII codes of the characters considered. Therefore, a character expressed in hexadecimal is obtained with 2 numbers that may assume values from “0” to “9” and from “A” to “F”. “**ckck**” is the ASCII code of the two hexadecimal digits

CR.....1 character of end string (13 ASCII)

In case of negative weight, the first character from the left of the weight characters takes on the value “-” (minus sign - ASCII 45).

In case of an error or alarm, the 6 characters of the gross weight are substituted by the messages found in the table in the ALARMS section.

FAST TRANSMISSION VIA EXTERNAL CONTACT: it is possible to transmit the weight a single time, by closing an input for no more than a second (see **INPUT AND OUTPUT CONFIGURATION** and **SERIAL COMMUNICATION SETTINGS**).

ASCII BIDIRECTIONAL PROTOCOL

The instrument replies to the requests sent from a PC/PLC.

It is possible to set a waiting time for the instrument before it transmits a response (see *dELAY* parameter in the **SERIAL COMMUNICATION SETTINGS** section).

- *Mod Ed*: communication compatible with TD RS485 instruments

Captions:

\$Beginning of a request string (36 ASCII)
& or **&&**Beginning of a response string (38 ASCII)
aa2 characters of instrument address (48 – 57 ASCII)
!1 character to indicate the correct reception (33 ASCII)
?1 character to indicate a reception error (63 ASCII)
#1 character to indicate an error in the command execution (23 ASCII)
ckck2 ASCII characters of Check-Sum (for further information, see **CHECK-SUM CALCULATION**)
CR1 character for string end (13 ASCII)
****1 character of separation (92 ASCII)

SETPOINT PROGRAMMING

Warning: the new values of setpoint are active immediately. The PC

transmits the ASCII string: **\$aaxxxxxxyckckCR**

where: **xxxxxx**6 characters for the setpoint value (48 – 57 ASCII)

y = Aset the value in the setpoint 1

y = Bset the value in the setpoint 2

y = Cset the value in the setpoint 3

Possible instrument responses:

- correct reception: **&&aa!\ckckCR**
- incorrect reception: **&&aa?\ckckCR**

Example: to set 500 in setpoint number 3, the PC must transmit the following command: **\$01000500C47 (Cr)**

SETPOINT STORAGE IN EEPROM MEMORY

The setpoint are stored in the RAM memory and lost upon instrument power off. It is necessary to send a special command to save them permanently in the EEPROM memory. Please note that the writing number allowed in the EEPROM memory is limited (about 100000).

The PC transmits the ASCII string: **\$aaMEMckckCR**

Possible instrument responses:

- correct reception: **&&aa!\ckckCR**
- incorrect reception: **&&aa?\ckckCR**

READING WEIGHT, SETPOINT AND PEAK (IF PRESENT) FROM PC

The PC transmits the ASCII string: **\$aajckckCR**

where: **j** = a.....to read setpoint 1

j = b.....to read setpoint 2

j = c.....to read setpoint 3

j = t.....to read gross weight

j = n.....to read net weight

j = p..... to read the gross weight peak if the *ASCII 1* parameter is set as *NOdu60*, if the *ASCII 1* parameter is set to *NOd td* the gross weight will be read.

To read the points, set the *FS_tEO* parameter equal to 50000

Possible instrument responses:

- correct reception: **&aaxxxxxxj\ckckCR**
- incorrect reception: **&&aa?\ckckCR**
- In case of peak not configured: **&aa#CR**

where: **xxxxxx**.....6 characters of the required weight value

Notes: in case of negative weight, the first character from the left of the weight characters takes on the value “-” (minus sign - ASCII 45). If the weight value is under -99999, the minus sign “-” is sent alternated with the most significant figure.

Error messages:

If there is an instrument alarm for exceeding 110% of the full scale or 9 divisions above the value of the parameter \overline{PASS} , the instrument will send the string:

&aassO-Lst\ckck

If there is an instrument alarm due to faulty connection of the load cells or another alarm, the instrument will send:

&aassO-Fst\ckck

where: **s**.....1 separator character (32 ASCII – space)

Generally refer to the **ALARMS** section.

SEMI-AUTOMATIC ZERO (WEIGHT ZERO-SETTING FOR SMALL VARIATIONS)

The PC transmits the ASCII string: **\$aaZEROckckCR**

Possible instrument responses:

- correct reception: **&&aa!\ckckCR**
- incorrect reception: **&&aa?\ckckCR**
- the current weight is over the maximum resettable value: **&aa#CR**

SWITCHING FROM GROSS TO NET WEIGHT

The PC transmits the ASCII string: **\$aaNETckckCR**

Possible instrument responses:

- correct reception: **&&aa!\ckckCR**
- incorrect reception: **&&aa?\ckckCR**

SWITCHING FROM NET TO GROSS WEIGHT

The PC transmits the ASCII string: **\$aaGROSSckckCR**

Possible instrument responses:

- correct reception: **&&aa!\ckckCR**
- incorrect reception: **&&aa?\ckckCR**

READING OF DECIMALS AND DIVISION NUMBER

The PC transmits the ASCII string: **\$aaDckckCR**

Possible instrument responses:

- correct reception: **&aaxy\ckckCR**
- incorrect reception: **&&aa?\ckckCR**

where: **x**.....numberofdecimals

y = 3 for division value = 1

y = 4 for division value = 2

y = 5 for division value = 5

y = 6 for division value = 10

y = 7 for division value = 20

y = 8 for division value = 50

y = 9 for division value = 100

TARE ZERO-SETTING

The PC transmits the ASCII string: **\$aazckckCR**

where: **z**.....command of weight zero-setting (122 ASCII)

Possible instrument responses:

- correct reception: **&aaxxxxxt\ckckCR**
- incorrect reception: **&&aa?\ckckCR**
- the gross weight is not displayed on the instrument: **&aa#CR**

where: **xxxxxx**.....6 characters to indicate the required weight value

t.....character to indicate the weight (116 ASCII)

Example: zeroing the weight of the instrument with address 2

For the calibration you have to make sure that the system is unloaded or that the instrument measures a signal equal to the mV in the same condition:

query: **\$02z78 (Cr)**

response: **&02000000t\76 (Cr)**

If the zeroing works correctly the instrument sends the zeroed weight value (“000000”).



The calibration values are stored permanently in the EEPROM memory and the number of allowed writings is limited (about 100000).

REAL CALIBRATION (WITH SAMPLE WEIGHT)

After the tare zero-setting, this function will allow the operator to check the calibration obtained by using sample weights and automatically correct any change between the displayed value and the actual value.

Load a sample weight onto the weighing system that is at least 50% of the Full Scale, or simulate a corresponding mV signal to the instrument.

The PC transmits the ASCII string: **\$asxxxxxckckCR**

where: **s**.....calibration command (115 ASCII)

xxxxxx 6 characters to indicate the value of sample weight

Possible instrument responses:

- correct reception: **&axxxxxt\ckckCR**
- incorrect reception or full scale equal to zero: **&&aa?\ckckCR**

where: **t**.....character of gross weight identification (116 ASCII)

xxxxxx 6 characters to indicate the value of current weight

In case of correct reception, the read value has to be equal to the sample weight.

Example: calibration of the instrument no. 1 with a sample weight of 20000 kg:

query: **\$01s02000070 (Cr)**

response: **&01020000t\77 (Cr)**

In case of correct calibration, the read value has to be “020000”.

KEYPAD LOCK (BLOCK ACCESS TO THE INSTRUMENT)

The PC transmits the ASCII string: **\$aaKEYckckCR**

Possible instrument responses:

- correct reception: **&&aa!\ckckCR**
- incorrect reception: **&&aa?\ckckCR**

KEYPAD UNLOCK

The PC transmits the ASCII string: **\$aaFREckckCR**

Possible instrument responses:

- correct reception: **&&aa!\ckckCR**
- incorrect reception: **&&aa?\ckckCR**

DISPLAY AND KEYPAD LOCK

The PC transmits the ASCII string: \$aaKDISckckCR Possible

instrument responses:

- correct reception: &&aa!\ckckCR
- incorrect reception: &&aa?\ckckCR

CHECK-SUM CALCULATION

The two ASCII characters (**ckck**) are the representation of a hexadecimal digit in ASCII characters. The check digit is calculated by executing the operation of XOR (exclusive OR) of 8-bit ASCII codes of only the string underlined.

The procedure to perform the calculation of check-sum is the following:

- Consider only the string characters highlighted with underlining
- Calculate the exclusive OR (XOR) of 8-bit ASCII codes of the characters

Example:

character	decimal ASCII code	hexadecimal ASCII code	binary ASCII code
0	48	30	00110000
1	49	31	00110001
t	116	74	01110100
XOR =	117	75	01110101

- The result of the XOR operation expressed in hexadecimal notation is made up of 2 hexadecimal digit (that is, numbers from 0 to 9 and/or letters from A to F). In this case the hexadecimal code is 0x75.
- The checksum is made up of the 2 characters that represent the result of the XOR operation in hexadecimal notation (in our example the character "7" and the character "5").

MODBUS-RTU PROTOCOL

The MODBUS-RTU protocol allows the management of the reading and writing of the following registries according to the specifications found on the reference document for this **Modicon PI-MBUS-300** standard.

To select the MODBUS-RTU communication see the **SERIAL COMMUNICATION SETTINGS** section.

Check if the *master* MODBUS-RTU in use (or the development tool) requires the disclosure of registers based on 40001 or 0. In the first case the registers numbering corresponds to the one in the table. In the second case the register must be determined as the value in the table minus 40001. **Example:** the register 40028 shall be reported as 27 (= 40028-40001).

When specifically indicated, certain data will be written directly in the EEPROM type memory. This memory has a limited number of writing operations (100000), therefore it is necessary to pay particular attention not to execute unnecessary operations on said locations. The instrument makes sure that no writing occurs if the value to be memorized is equal to the value in memory.

The numerical data found below is expressed in decimal notation. if the prefix 0x is entered the notation will be hexadecimal.

MODBUS-RTU DATA FORMAT

The data received and transmitted by way of the MODBUS-RTU protocol have the following characteristics:

- 1 start bit
- 8 bit of data, *least significant bit* sent first
- Settable parity bit
- Settable stop bit

FUNCTIONS SUPPORTED IN MODBUS

Among the commands available in the MODBUS-RTU protocol, only the following are utilized for management of communication with the instrument, other commands could be incorrectly interpreted and generate errors or blocks of the system:

FUNCTIONS	DESCRIPTION
03 (0x03)	READ HOLDING REGISTER (READ PROGRAMMABLE REGISTERS)
16 (0x10)	PRESET MULTIPLE REGISTERS (WRITE MULTIPLE REGISTERS)

Interrogation frequency is linked to the communication speed set (the instrument stands by for at least 3 bytes before starting calculations for an eventual response to the interrogation query). The **DELAY** parameter present in the **SERIAL COMMUNICATION SETTING** section,

allows the instrument to respond with a further delay and this directly influences the number of interrogations possible in the unit of time.

For additional information on this protocol refer to the general technical specifications PI_MBUS_300.

General queries and answers to and from one slave instrument are composed as follows:

FUNCTION 3: Read holding registers (READ PROGRAMMABLE REGISTERS)

QUERY

Address	Function	1st register address	No. registers	2 byte
A	0x03	0x0000	0x0002	CRC

Tot. byte = 8 *RESPONSE*

Address	Function	No. bytes	1st register	2nd register	2 byte
A	0x03	0x04	0x0064	0x00C8	CRC

Tot. byte = 3+2*No. registers+2

where: No. registers ..number of Modbus registers to write beginning from the address no. 1
 No. byte.....number of bytes of the following data

FUNCTION 16: Preset multiple registers (WRITE MULTIPLE REGISTERS)

QUERY

Address	Function	1st reg. add.	No. reg.	No. bytes	Val.reg.1	Val.reg.2	2 byte
A	0x10	0x0000	0x0002	0x04	0x0000	0x0000	CRC

Tot. byte = 7+2*No.

registers+2 *RESPONSE*

Address	Function	1st reg. address	No. reg.	2 byte
A	0x10	0x0000	0x0002	CRC

Tot. byte = 8

where: No. registers ..number of Modbus registers to read beginning from the address no. 1
 No. byte number of bytes of the following data
 Val.reg.1contents of the register beginning from the first

The response contains the number of registers modified beginning from the address no. 1.

COMMUNICATION ERROR MANAGEMENT

The communication strings are controlled by way of the CRC (Cyclical Redundancy Check). In case of communication error the slave will not respond with any string. The master must consider a time-out for reception of the answer. If it does not receive an answer it deduces that there has been a communication error.

In the case of the string received correctly but not executable, the slave responds with an EXCEPTIONAL RESPONSE. The "Function" field is transmitted with the msb at 1.

EXCEPTIONAL RESPONSE

Address	Function	Code	2 byte
A	Funct + 0x80		CRC

CODE	DESCRIPTION
1	ILLEGAL FUNCTION (the function is not valid or is not supported)
2	ILLEGAL DATA ADDRESS (the specified data address is not available)
3	ILLEGAL DATA VALUE (the data received has an invalid value)

LIST OF AVAILABLE REGISTERS

The MODBUS-RTU protocol implemented on this instrument can manage a maximum of 32 registers read and written in a single query or response.

R.....the register may only be read

W.....the register may only be written

R/Wthe register may be both read and written

H.....high half of the DOUBLE WORD containing the number

L.....low half of the DOUBLE WORD containing the number

Register	Description	Saving in EEPROM	Access
40001	Firmware version	-	R
40002	Instrument type	-	R
40003	Year of manufacture	-	R
40004	Serial number	-	R
40005	Program type	-	R
40006	COMMAND REGISTER	NO	W
40007	STATUS REGISTER	-	R
40008	GROSS WEIGHT H	-	R
40009	GROSS WEIGHT L	-	R
40010	NET WEIGHT H	-	R
40011	NET WEIGHT L	-	R
40012	PEAK WEIGHT H	-	R

40013	PEAK WEIGHT L	-	R
40014	Divisions and Units of measure	-	R
40015	Coefficient H	-	R
40016	Coefficient L	-	R
40017	SETPOINT 1 H	Only after command 99 of the Command Register	R/W
40018	SETPOINT 1 L		R/W
40019	SETPOINT 2 H		R/W
40020	SETPOINT 2 L		R/W
40021	SETPOINT 3 H		R/W
40022	SETPOINT 3 L		R/W
40023	HYSTERESIS 1 H		R/W
40024	HYSTERESIS 1 L		R/W
40025	HYSTERESIS 2 H		R/W
40026	HYSTERESIS 2 L		R/W
40027	HYSTERESIS 3 H		R/W
40028	HYSTERESIS 3 L		R/W
40029	INPUTS	-	R
40030	OUTPUTS	NO	R/W
40037	Sample weight for instrument calibration H	Use with command 101 of the Command Register	R/W
40038	Sample weight for instrument calibration L		R/W
40043	Weight value corresponding to ZERO of the analog output H	Only after command 99 of the Command Register	R/W
40044	Weight value corresponding to ZERO of the analog output L		R/W
40045	Weight value corresponding to the full scale of the analog output H		R/W
40046	Weight value corresponding to the full scale of the analog output L		R/W
40073	Preset tare H	Use with command 130 of the Command Register	R/W
40074	Preset tare L		R/W

WARNING: at the time of writing the setpoint values are saved to RAM (they will be lost upon the next power-off). To store them permanently to EEPROM so that they are maintained at power-on, the 99 command of the Command Register must be sent.

STATUS REGISTER (40007)

Bit 0	Load cell error	Bit 8	Net weight negative sign
Bit 1	AD converter malfunction	Bit 9	Peak weight negative sign
Bit 2	Maximum weight exceeded by 9 divisions	Bit 10	Net display mode
Bit 3	Gross weight higher than 110% of full scale	Bit 11	Weight stability
Bit 4	Gross weight beyond 999999 or less than -999999	Bit 12	Weight within $\pm\frac{1}{4}$ of a division around ZERO
Bit 5	Net weight beyond 999999 or less than -999999	Bit 13	
Bit 6		Bit 14	
Bit 7	Gross weight negative sign	Bit 15	

INPUTS REGISTER (40029) (read only)

Bit 0	INPUT 1 status
Bit 1	INPUT 2 status
Bit 2	
Bit 3	
Bit 4	
Bit 5	
Bit 6	
Bit 7	
Bit 8	
Bit 9	
Bit 10	
Bit 11	
Bit 12	
Bit 13	
Bit 14	
Bit 15	

OUTPUTS REGISTER (40030) (read/write)

Bit 0	OUTPUT 1 status
Bit 1	OUTPUT 2 status
Bit 2	OUTPUT 3 status 3
Bit 3	
Bit 4	
Bit 5	
Bit 6	
Bit 7	
Bit 8	
Bit 9	
Bit 10	
Bit 11	
Bit 12	
Bit 13	
Bit 14	
Bit 15	

The output status can be read at any time but can be set (written) only if the output has been set as **PLC** (see **INPUTS AND OUTPUTS CONFIGURATION**). Otherwise, the outputs will be managed according to the current weight status with respect to the relevant setpoint.

DIVISIONS AND UNITS OF MEASURE REGISTER (40014)

This register contains the current setting of the divisions (parameter *dl U1 5*) and of the units of measure (parameter *Un1 1*).

H Byte	L Byte
Unit of measure	Division

Use this register together with the Coefficient registers to calculate the value displayed by the instrument.

Least significant byte (L Byte)

Most significant byte (H Byte)

Division value	Divisor	Decimals
0	100	0
1	50	0
2	20	0
3	10	0
4	5	0
5	2	0
6	1	0
7	0.5	1
8	0.2	1
9	0.1	1
10	0.05	2
11	0.02	2
12	0.01	2
13	0.005	3
14	0.002	3
15	0.001	3
16	0.0005	4
17	0.0002	4
18	0.0001	4

Unit of measure value	Unit of measure description	Coefficient effect on the read gross weight
0	Kilograms	No effect
1	Grams	No effect
2	Tons	No effect
3	Pounds	No effect
4	Newton	Multiplies
5	Litres	Divides
6	Bar	Multiplies
7	Atmospheres	Multiplies
8	Pieces	Divides
9	Newton Metres	Multiplies
10	Kilogram Metres	Multiplies
11	Other	Multiplies

POSSIBLE COMMANDS TO BE SENT TO COMMAND REGISTER (40006)

0	No command	1	
6		7	SEMI-AUTOMATIC TARE enabling (net weight displaying)
8	SEMI-AUTOMATIC ZERO	9	SEMI-AUTOMATIC TARE disabling (gross weight displaying)
20		21	Keypad lock
22	Keypad and display unlock	23	Keypad and display lock
98		99	Save data in EEPROM
100	TARE WEIGHT ZERO SETTING for calibration	101	Sample weight storage for calibration
130	Preset tare enabling	131	Reserved

ANALOG OUTPUT SETTING

Write the weight into registers “Weight value corresponding to the Full Scale of the analog output H” (40045) and “Weight value corresponding to the Full Scale of the analog output L” (40046), otherwise write the weight into registers “Weight value corresponding to ZERO of the analog output H” (40043) and “Weight value corresponding to ZERO of the analog output L” (40044). After writing the value, send the command 99 from the Command Register to save it to EEPROM memory.

REAL CALIBRATION COMMANDS (WITH SAMPLE WEIGHTS)

- Unload the system and reset to zero the displayed weight value with the command 100 “TARE WEIGHT ZERO SETTING for calibration” of the Command Register.
- Load a sample weight on the system and send its value to the registers 40037-40038.
- To save the value, send the command 101 “Sample weight storage for calibration” to the Command Register.

If the operation is successfully completed, the two sample weight registers are set to zero.

In order to correctly set the sample weight, consider the value of the Division register (40014). **Example:** to set the sample weight to 100 kg and the division 0.001, then the value to enter is 100000 ($100 / 0.001 = 100000$).

COMMUNICATION EXAMPLES

The numerical data below is expressed in hexadecimal notation with the prefix h.

EXAMPLE 1

Command for multiple writing of registers (command 16, h10 hexadecimal).

Assuming that we wish to write the value 0 to the register 40017 and the value 2000 to the register 40018, the string to generate would be:

h01 h10 h00 h10 h00 h02 h04 h00 h00 h07 hD0 hF1 h0F

The instrument will respond with the string:

h01 h10 h00 h10 h00 h02 h40 h0D

Query field name	hex	Response field name	hex
Instrument address	h01	Instrument address	h01
Function	h10	Function	h10
Address of the first register H	h00	Address of the first register H	h00
Address of the first register L	h10	Address of the first register L	h10
Number of registers H	h00	Number of registers H	h00
Number of registers L	h02	Number of registers L	h02
Byte count	h04	CRC16 L	h40
Datum 1 H	h00	CRC16 H	h0D
Datum 1 L	h00		
Datum 2 H	h07		
Datum 2 L	hD0		
CRC16 L	hF1		
CRC16 H	h0F		

EXAMPLE 2

Command for multiple writing of registers (command 16, h10 hexadecimal).

Assuming that we wish to write two setpoint values on the instrument, at 2000 (setpoint 1: 40017-40018) and 3000 (setpoint 2: 40019-40020) respectively, the following string must be sent:

h01 h10 h00 h10 h00 h04 h08 h00 h00 h07 hD0 h00 h00 h0B hB8 hB0 hA2

The instrument will respond with the string:

h01 h10 h00 h10 h00 h04 hC0 h0F

Query field name	hex	Response field name	hex
Instrument address	h01	Instrument address	h01
Function	h10	Function	h10
Address of the first register H	h00	Address of the first register H	h00
Address of the first register L	h10	Address of the first register L	h10
Number of registers H	h00	Number of registers H	h00
Number of registers L	h04	Number of registers L	h04
Byte count	h08	CRC16 L	hC0
Datum 1 H	h00	CRC16 H	h0F
Datum 1 L	h00		
Datum 2 H	h07		
Datum 2 L	hD0		
Datum 3 H	h00		
Datum 3 L	h00		
Datum 4 H	h0B		
Datum 4 L	hB8		
CRC16 L	hB0		
CRC16 H	hA2		

EXAMPLE 3

Multiple commands reading for registers (command 3, h03 hexadecimal).

Assuming that we wish to read the gross weight value (in the example 4000) and net weight value (in the example 3000), reading from address 40008 to address 40011 must be performed by sending the following string:

h01 h03 h00 h07 h00 h04 hF5 hC8

The instrument will respond with the string:

h01 h03 h08 h00 h00 h0F hA0 h00 h00 h0B hB8 hB3 h30

Query field name	hex	Response field name	hex
Instrument address	h01	Instrument address	h01
Function	h03	Function	h03
Address of the first register H	h00	Byte count	h08
Address of the first register L	h07	Datum 1 H	h00
Number of registers H	h00	Datum 1 L	h00
Number of registers L	h04	Datum 2 H	h0F
CRC16 L	hF5	Datum 2 L	hA0
CRC16 H	hC8	Datum 3 H	h00
		Datum 3 L	h00
		Datum 4 H	h0B
		Datum 4 L	hB8
		CRC16 L	hB3
		CRC16 H	h30

For additional examples regarding the generation of correct control characters (CRC16) refer to the manual **Modicon PI-MBUS-300**.

CANOPEN

TECHNICAL SPECIFICATIONS AND CONNECTIONS

Baud rate [kb/s]	10, 20, 50, 125, 250, 500, 800, 1000
Node ID	1÷127
Terminals legend	10 CAN GND 11 CAN L 12 CAN SHLD 13 CAN H 14 NC

The instrument features a CANopen port that allows the exchange of weight and main parameters.

INSTRUMENT SETUP

 +  → *CAnOPn*

- *Addr* (default: 1): set the instrument address in the CANopen network.
- *BAUD* (default: 1000 kb/s): set the instrument baud rate in the CANopen network.
- *SUAP* (default: *n0*): it allows to select the reading/writing of the byte in LITTLE-ENDIAN or BIG-ENDIAN mode.
 - *YES*: BIG ENDIAN
 - *n0*: LITTLE ENDIAN

In order to apply the changes, turn the instrument off, wait for 10 seconds and turn it back on.

PC/PLC SETUP

The instrument works as *slave* in a synchronous CANopen network (activate the SYNC object on the network master).

Load the eds file attached to the instrument to the CANopen *master* development system.

When configuring CANopen Guard Time and Lifetime Factor, set values 100 ms and 4.

The data exchanged by the instrument are:

Output Data from instrument (Reading)	Index	Sub-Index	Data type	Addresses
Gross Weight [4 byte]	4100	01	UNSIGNED32	0x0000-0x0003
Net Weight [4byte]	4100	02	UNSIGNED32	0x0004-0x0007
Exchange Register [4 byte]	4101	01	UNSIGNED32	0x0008-0x000B
Status Register [2 byte]	4101	02	UNSIGNED16	0x000C-0x000D
Digital Inputs status [1 byte]	4101	03	UNSIGNED8	0x000E
Digital Outputs status [1 byte]	4101	04	UNSIGNED8	0x000F

Input Data to instrument (Writing)	Index	Sub-Index	Data type	Addresses
Command Register [2 byte]	4000	01	UNSIGNED16	0x0000-0x0001
Digital Outputs Command [2 byte]	4000	02	UNSIGNED16	0x0002-0x0003
Exchange Register [4 byte]	4000	03	UNSIGNED32	0x0004-0x0007

GROSS WEIGHT, NET WEIGHT: the weight values are expressed as positive integer numbers, including decimal figures, but without decimal point. Read the Status Register to obtain information about sign and possible errors on the weight.

DIGITAL INPUTS STATUS

Bit 0	INPUT 1 status
Bit 1	INPUT 2 status
Bit 2	
Bit 3	
Bit 4	
Bit 5	
Bit 6	
Bit 7	

DIGITAL OUTPUTS STATUS

Bit 0	OUTPUT 1 status
Bit 1	OUTPUT 2 status
Bit 2	OUTPUT 3 status
Bit 3	
Bit 4	
Bit 5	
Bit 6	
Bit 7	

Bit = 1: high input; Bit = 0: low input

DIGITAL OUTPUT COMMANDS

Allows control of the outputs set to *PLC* mode (see **INPUT AND OUTPUT CONFIGURATION**):

Bit 0	OUTPUT 1 status	Bit 8	
Bit 1	OUTPUT 2 status	Bit 9	
Bit 2	OUTPUT 3 status	Bit 10	
Bit 3		Bit 11	
Bit 4		Bit 12	
Bit 5		Bit 13	
Bit 6		Bit 14	
Bit 7		Bit 15	Force outputs

Bit = 1: output is closed; Bit = 0: output is open



Setting bit 15 to 1 on the PLC, the master takes control of all the outputs, whatever their setting.

STATUS REGISTER

Bit 0	Load cell error	Bit 8	Net weight negative sign
Bit 1	AD converter malfunction	Bit 9	Peak weight negative sign
Bit 2	Maximum weight exceeded by 9 divisions	Bit 10	Net display mode
Bit 3	Gross weight higher than 110% of full scale	Bit 11	Weight stability
Bit 4	Gross weight beyond 999999 or less than -999999	Bit 12	Weight within $\pm\frac{1}{4}$ of a division around ZERO
Bit 5	Net weight beyond 999999 or less than -999999	Bit 13	
Bit 6		Bit 14	
Bit 7	Gross weight negative sign	Bit 15	

POSSIBLE COMMANDS TO BE SENT TO THE COMMAND REGISTER

0	No command	1	
6		7	SEMI-AUTOMATIC TARE enabling (net weight displaying)
8	SEMI-AUTOMATIC ZERO	9	SEMI-AUTOMATIC TARE disabling (gross weight displaying)
20		21	Keypad lock
22	Keypad and display unlock	23	Keypad and display lock
86		87**	Preset tare reading
88**	Preset tare writing	89	
90**	Setpoint 1 reading	91**	Setpoint 2 reading
92**	Setpoint 3 reading	93**	Setpoint 1 writing
94**	Setpoint 2 writing	95**	Setpoint 3 writing
98		99	Save data in EEPROM
100	TARE WEIGHT ZERO SETTING for calibration	101	Sample weight storage for calibration
102**	Sample Weight reading	103**	Sample Weight writing

***) The instrument features two Exchange Registers (one for reading and one for writing), which must be used together with the Command Register in order to access these values. These are the procedures to follow:

- READING: send the desired datum reading command (e.g.: 90 for "Setpoint 1 reading") to the Command Register and read the content of the Exchange Register.
- WRITING: write the value that you want to set in the Exchange Register and send the desired datum writing command (e.g.: 93 for "Setpoint 1 writing") to the Command Register.

If it is necessary to execute the same command twice consecutively, send command 0 between the first command and the following one.

Setpoint Reading/Writing

The setpoints are weight values expressed as positive integer numbers, include decimal figures but without decimal point.

Setpoints are stored to RAM and lost upon instrument power off. To save them in EEPROM, so that they are maintained upon instrument power on, it is necessary to send the command 99 "Save data in EEPROM" of the Command Register.

REAL CALIBRATION COMMANDS (WITH SAMPLE WEIGHTS)

- Unload the system and reset to zero the displayed weight value with the command 100 “TARE WEIGHT ZERO SETTING for calibration” of the Command Register.
- Load a sample weight on the system, write its value into the Exchange Register and send the command 103 “Sample Weight writing” to the Command Register;
- To save the value send the command 101 “Sample weight storage for calibration” to the Command Register.

If the operation is successfully completed, the command 102 “Sample Weight reading” returns a value equal to zero.

DEVICENET

TECHNICAL SPECIFICATIONS AND CONNECTIONS

Baud rate [kb/s]	125, 250, 500
Addresses	1-63
Terminals legend	10 CAN V - 11 CAN L 12 CAN SHLD 13 CAN H 14 CAN V +

It is necessary to activate the termination resistance on the two devices located at the ends of the network closing the jumper.

The instrument features a DeviceNet port that allows to exchange the weight and the main parameters with a DeviceNet *master*.

INSTRUMENT SETUP

 +  → *dEUnEt*

- **Addr** (default: 1): set the instrument address in the DeviceNet network.
- **bAUd** (default: 500 kb/s): set the instrument baud rate in the DeviceNet network.
- **SUAP** (default: *n0*): it allows to select the reading/writing of the byte in LITTLE-ENDIAN or BIG-ENDIAN mode
 - **YES**: BIG ENDIAN
 - **n0**: LITTLE ENDIAN

In order to apply the changes, turn the instrument off, wait for 10 seconds and turn it back on.

PC/PLC SETUP

The instrument works as *slave* in a DeviceNet network.

Load the eds file attached to the instrument to the DeviceNet *master* development system.

The data exchanged by the instrument are:

Output Data from instrument (Reading)	Addresses
Gross Weight [4 byte]	0x0000-0x0003
Net Weight [4byte]	0x0004-0x0007
Exchange Register [4 byte]	0x0008-0x000B
Status Register [2 byte]	0x000C-0x000D
Digital Inputs status [1 byte]	0x000E
Digital Outputs status [1 byte]	0x000F

Input Data to instrument (Writing)	Addresses
Command Register [2 byte]	0x0000-0x0001
Digital Outputs Command [2 byte]	0x0002-0x0003
Exchange Register [4 byte]	0x0004-0x0007

GROSS WEIGHT, NET WEIGHT: the weight values are expressed as positive integer numbers, including decimal figures, but without decimal point. Read the Status Register to obtain information about sign and possible errors on the weight.

DIGITAL INPUTS STATUS

Bit 0	INPUT 1 status
Bit 1	INPUT 2 status
Bit 2	
Bit 3	
Bit 4	
Bit 5	
Bit 6	
Bit 7	

Bit = 1: high input; Bit = 0: low input

DIGITAL OUTPUTS STATUS

Bit 0	OUTPUT 1 status
Bit 1	OUTPUT 2 status
Bit 2	OUTPUT 3 status
Bit 3	
Bit 4	
Bit 5	
Bit 6	
Bit 7	

DIGITAL OUTPUT COMMANDS

Allows control of the outputs set to *PLC* mode (see **INPUT AND OUTPUT CONFIGURATION**):

Bit 0	OUTPUT 1 status	Bit 8	
Bit 1	OUTPUT 2 status	Bit 9	
Bit 2	OUTPUT 3 status	Bit 10	
Bit 3		Bit 11	
Bit 4		Bit 12	
Bit 5		Bit 13	
Bit 6		Bit 14	
Bit 7		Bit 15	Force outputs

Bit = 1: output is closed; Bit = 0: output is open



Setting bit 15 to 1 on the PLC, the master takes control of all the outputs, whatever their setting.

STATUS REGISTER

Bit 0	Load cell error	Bit 8	Net weight negative sign
Bit 1	AD converter malfunction	Bit 9	Peak weight negative sign
Bit 2	Maximum weight exceeded by 9 divisions	Bit 10	Net display mode
Bit 3	Gross weight higher than 110% of full scale	Bit 11	Weight stability
Bit 4	Gross weight beyond 999999 or less than -999999	Bit 12	Weight within $\pm\frac{1}{4}$ of a division around ZERO
Bit 5	Net weight beyond 999999 or less than -999999	Bit 13	
Bit 6		Bit 14	
Bit 7	Gross weight negative sign	Bit 15	

POSSIBLE COMMANDS TO BE SENT TO THE COMMAND REGISTER

0	No command	1	
6		7	SEMI-AUTOMATIC TARE enabling (net weight displaying)
8	SEMI-AUTOMATIC ZERO	9	SEMI-AUTOMATIC TARE disabling (gross weight displaying)
20		21	Keypad lock
22	Keypad and display unlock	23	Keypad and display lock
86		87**	Preset tare reading
88**	Preset tare writing	89	
90**	Setpoint 1 reading	91**	Setpoint 2 reading
92**	Setpoint 3 reading	93**	Setpoint 1 writing
94**	Setpoint 2 writing	95**	Setpoint 3 writing
98		99	Save data in EEPROM
100	TARE WEIGHT ZERO SETTING for calibration	101	Sample weight storage for calibration
102**	Sample Weight reading	103**	Sample Weight writing

***) The instrument features two Exchange Registers (one for reading and one for writing), which must be used together with the Command Register in order to access these values. These are the procedures to follow:

- READING: send the desired datum reading command (e.g.: 90 for "Setpoint 1 reading") to the Command Register and read the content of the Exchange Register.
- WRITING: write the value that you want to set in the Exchange Register and send the desired datum writing command (e.g.: 93 for "Setpoint 1 writing") to the Command Register.

If it is necessary to execute the same command twice consecutively, send command 0 between the first command and the following one.

Setpoint Reading/Writing

The setpoints are weight values expressed as positive integer numbers, include decimal figures but without decimal point.

Setpoints are stored to RAM and lost upon instrument power off. To save them in EEPROM, so that they are maintained upon instrument power on, it is necessary to send the command 99 "Save data in EEPROM" of the Command Register.

REAL CALIBRATION COMMANDS (WITH SAMPLE WEIGHTS)

- Unload the system and reset to zero the displayed weight value with the command 100 “TARE WEIGHT ZERO SETTING for calibration” of the Command Register.
- Load a sample weight on the system, write its value into the Exchange Register and send the command 103 “Sample Weight writing” to the Command Register;
- To save the value send the command 101 “Sample weight storage for calibration” to the Command Register.

If the operation is successfully completed, the command 102 “Sample Weight reading” returns a value equal to zero.

CC-LINK

TECHNICAL SPECIFICATIONS AND CONNECTIONS

Baud rate	156 k, 625 k, 2500 k, 5 M, 10 M
Addresses	1÷64
CC-LINK status led indications	off Timeout/reset steady red.....CC-LINK OK
Terminals legend	10 CCL DA 11 CCL DB 12 CCL DG 13 CCL SLD 14 CCL FG

To activate the termination resistance of CC-LINK network close the related jumper.

The instrument features a CC-LINK port that allows to exchange the weight and the main parameters with a CC-LINK *master*.

INSTRUMENT SETUP

 +  → [CCL] nH

- **Addr** (default: 1): set the instrument address in the CC-LINK network.
- **bAud** (default: 10 Mb/s): set the instrument baud rate in the CC-LINK network.

PC/PLC SETUP

The instrument works as Remote Device Station in a CC-LINK network and occupies 3 stations. Load the csp file attached to the instrument to the CC-LINK *master* development system. Insert and configure the INFCC-LINK in an existing project.

The data exchanged by the instrument are:

Output Data from instrument (Reading)	Addresses
Gross Weight [4 byte]	Wr0000 – Wr0001
Net Weight [4byte]	Wr0002 – Wr0003
Exchange Register [4 byte]	Wr0004 – Wr0005
Status Register [2 byte]	Wr0006
Digital Inputs status [2 byte]	Wr0007
Digital Outputs status [2 byte]	Wr0008
-	Wr0009-Wr000B

Input Data to instrument (Writing)	Addresses
Command Register [2 byte]	Ww0000
Digital Outputs Command [2 byte]	Ww0001
Exchange Register [4 byte]	Ww0002-Ww0003
-	Ww0004-Ww000B

GROSS WEIGHT, NET WEIGHT: the weight values are expressed as positive integer numbers, including decimal figures, but without decimal point. Read the Status Register to obtain information about sign and possible errors on the weight.

DIGITAL INPUTS STATUS

Bit 0	INPUT 1 status
Bit 1	INPUT 2 status
Bit 2	
Bit 3	
Bit 4	
Bit 5	
Bit 6	
Bit 7	

DIGITAL OUTPUTS STATUS

Bit 0	OUTPUT 1 status
Bit 1	OUTPUT 2 status
Bit 2	OUTPUT 3 status
Bit 3	
Bit 4	
Bit 5	
Bit 6	
Bit 7	

Bit = 1: high input; Bit = 0: low input

DIGITAL OUTPUT COMMANDS

Allows control of the outputs set to **PLC** mode (see **INPUT AND OUTPUT CONFIGURATION**):

Bit 0	OUTPUT 1 status	Bit 8	
Bit 1	OUTPUT 2 status	Bit 9	
Bit 2	OUTPUT 3 status	Bit 10	
Bit 3		Bit 11	
Bit 4		Bit 12	
Bit 5		Bit 13	
Bit 6		Bit 14	
Bit 7		Bit 15	Force outputs

Bit = 1: output is closed; Bit = 0: output is open



Setting bit 15 to 1 on the PLC, the master takes control of all the outputs, whatever their setting.

STATUS REGISTER

Bit 0	Load cell error	Bit 8	Net weight negative sign
Bit 1	AD converter malfunction	Bit 9	Peak weight negative sign
Bit 2	Maximum weight exceeded by 9 divisions	Bit 10	Net display mode
Bit 3	Gross weight higher than 110% of full scale	Bit 11	Weight stability
Bit 4	Gross weight beyond 999999 or less than -999999	Bit 12	Weight within $\pm\frac{1}{4}$ of a division around ZERO
Bit 5	Net weight beyond 999999 or less than -999999	Bit 13	
Bit 6		Bit 14	
Bit 7	Gross weight negative sign	Bit 15	

POSSIBLE COMMANDS TO BE SENT TO THE COMMAND REGISTER

0	No command	1	
6		7	SEMI-AUTOMATIC TARE enabling (net weight displaying)
8	SEMI-AUTOMATIC ZERO	9	SEMI-AUTOMATIC TARE disabling (gross weight displaying)
20		21	Keypad lock
22	Keypad and display unlock	23	Keypad and display lock
86		87**	Preset tare reading
88**	Preset tare writing	89	
90**	Setpoint 1 reading	91**	Setpoint 2 reading
92**	Setpoint 3 reading	93**	Setpoint 1 writing
94**	Setpoint 2 writing	95**	Setpoint 3 writing
98		99	Save data in EEPROM
100	TARE WEIGHT ZERO SETTING for calibration	101	Sample weight storage for calibration
102**	Sample Weight reading	103**	Sample Weight writing
130	Preset tare enabling	131	

***) The instrument features two Exchange Registers (one for reading and one for writing), which must be used together with the Command Register in order to access these values. These are the procedures to follow:

- READING: send the desired datum reading command (e.g.: 90 for "Setpoint 1 reading") to the Command Register and read the content of the Exchange Register.
- WRITING: write the value that you want to set in the Exchange Register and send the desired datum writing command (e.g.: 93 for "Setpoint 1 writing") to the Command Register.

If it is necessary to execute the same command twice consecutively, send command 0 between the first command and the following one.

Setpoint Reading/Writing

The setpoints are weight values expressed as positive integer numbers, include decimal figures but without decimal point.

Setpoints are stored to RAM and lost upon instrument power off; to save them in EEPROM, so that they are maintained upon instrument power on, it is necessary to send the command 99 "Save data in EEPROM" of the Command Register.

Preset tare

Write the preset tare value through the command 88 "Write preset tare". Send the command 130 "Enable preset tare" to enable the preset tare.

REAL CALIBRATION COMMANDS (WITH SAMPLE WEIGHTS)

- Unload the system and reset to zero the displayed weight value with the command 100 “TARE WEIGHT ZERO SETTING for calibration” of the Command Register.
- Load a sample weight on the system, write its value into the Exchange Register and send the command 103 “Sample Weight writing” to the Command Register;
- To save the value send the command 101 “Sample weight storage for calibration” to the Command Register.

If the operation is successfully completed, the command 102 “Sample Weight reading” returns a value equal to zero.

ETHERNET TCP/IP

TECHNICAL SPECIFICATIONS

Port	RJ45 10Base-T or 100Base-TX (auto-detect)
Link led indications	off No link amber 10 Mb/s green 100 Mb/s
Activity led indications	off No activity amber Half Duplex green Full Duplex

The instrument features an ethernet TCP/IP port that allows to exchange the weight and the main parameters in an ethernet network, for example with a PC.

INSTRUMENT SETUP

 +  → *EtHnEt*

- *IPAddr* (default: 192.8.0.141): set instrument IP address.
- *SubnEt* (default: 255.255.255.0): set instrument Subnet Mask.
- *GAteWAY* (default: 192.8.0.111): set Gateway address of Ethernet network.
- *PrOtE*: select communication protocol.
 - *nOnE*: disables any type of communication (default).
 - *ModBUS*: MODBUS-RTU protocol; possible addresses: from 1 to 99.
 - *ASCI I* : ASCII bidirectional protocol; possible addresses: from 1 to 99.
 - *PrOtEd*
 - *ContIn*: continuous weight transmission protocol, at the frequency set in *HErtz* item (from 10 to 300).
 - *PrOtE* (set: *PrOtE* = *nOnE*, *StOP* = 1).
 - *PrOtEd* (set: *PrOtE* = *nOnE*, *StOP* = 1).

- **WEBSITE**: see section **WEBSITE**.
- **Addr**: instrument address (from 1 to 99; default: 1).
- **BAUD**: transmission speed (2400, 4800, 9600, 19200, 38400, 115200; default: 9600).
- **HERTZ**: maximum transmission frequency (10 – 20 – 30 – 40 – 50 – 60 – 70 – 80 – 100 – 200 – 300; default: 10); to be set when the **CONTIN** transmission protocol is selected. Maximum setting frequency (**HERTZ**):
 - 20 Hz with minimum baud rate 2400 baud.
 - 40 Hz with minimum baud rate 4800 baud.
 - 80 Hz with minimum baud rate 9600 baud.
 - 100 Hz with minimum baud rate 19200 baud.
 - 200 Hz with minimum baud rate 38400 baud.
 - 300 Hz with minimum baud rate 38400 baud.
- **DELAY**: delay in milliseconds which elapses before the instrument replies (from 0 to 200 ms; default: 0).
- **PARITY**:
 - **none**: no parity (default).
 - **EVEN**: even parity.
 - **Odd**: odd parity.
- **STOP**: stop bit (1 – 2; default: 1).

In order to apply the changes, turn the instrument off, wait for 10 seconds and turn it back on.

PC SETUP

A PC can be connected by a virtual serial port to the instrument via Ethernet TCP/IP. To install the virtual COM port, use the CPR Manager included in the supply: run file *CPR.exe*. Add a serial port, set an IP address (host) and a TCP port (10001), then save.

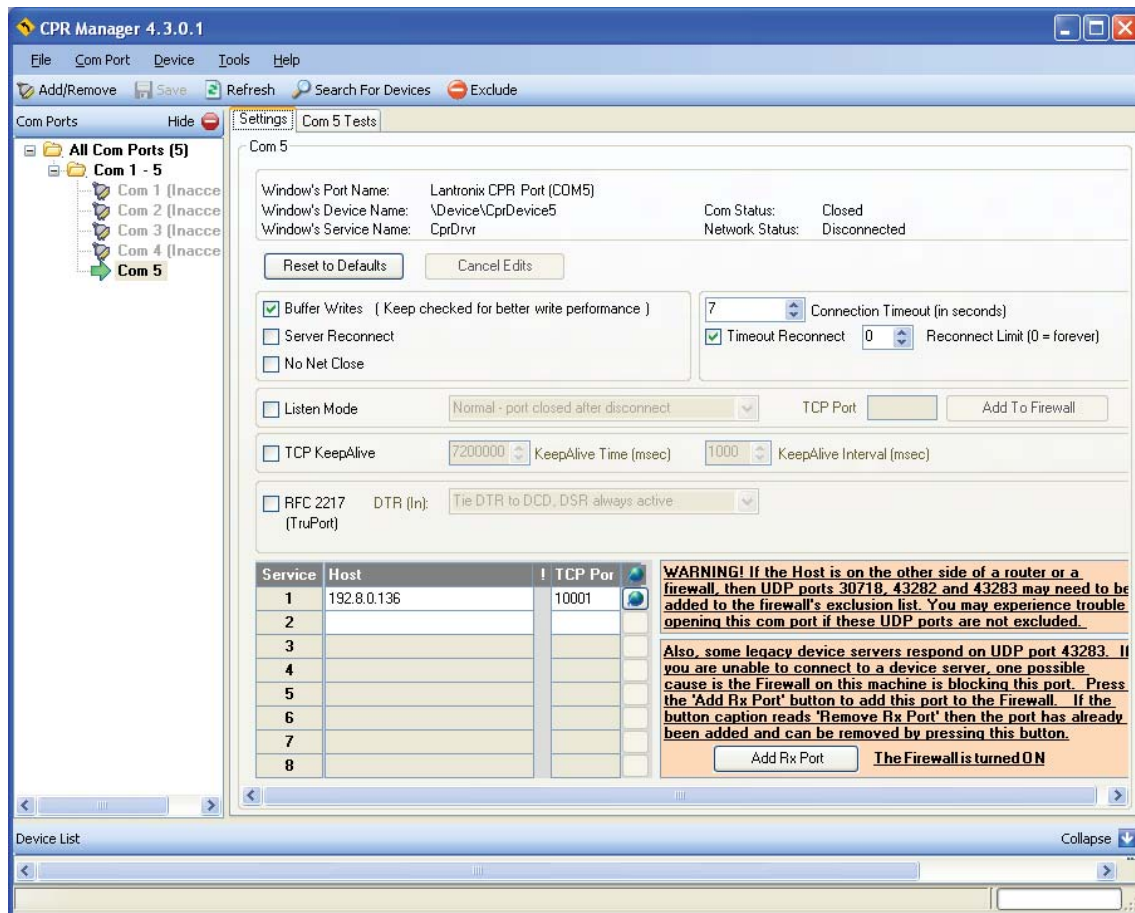

Use the just created virtual COM port to communicate with the instrument, using the protocol selected on it.

Alternatively connect to the instrument using a socket (e.g.: Winsock) on port 10001.

DIAGNOSTIC

To verify the Ethernet configuration of the instrument, you can install the application Lantronix DeviceInstaller on a PC with Microsoft Windows operating system (run file *DevInst.exe*). Connect PC and instrument via LAN (point-to-point or through hub/switch), then run the application and click on Search:

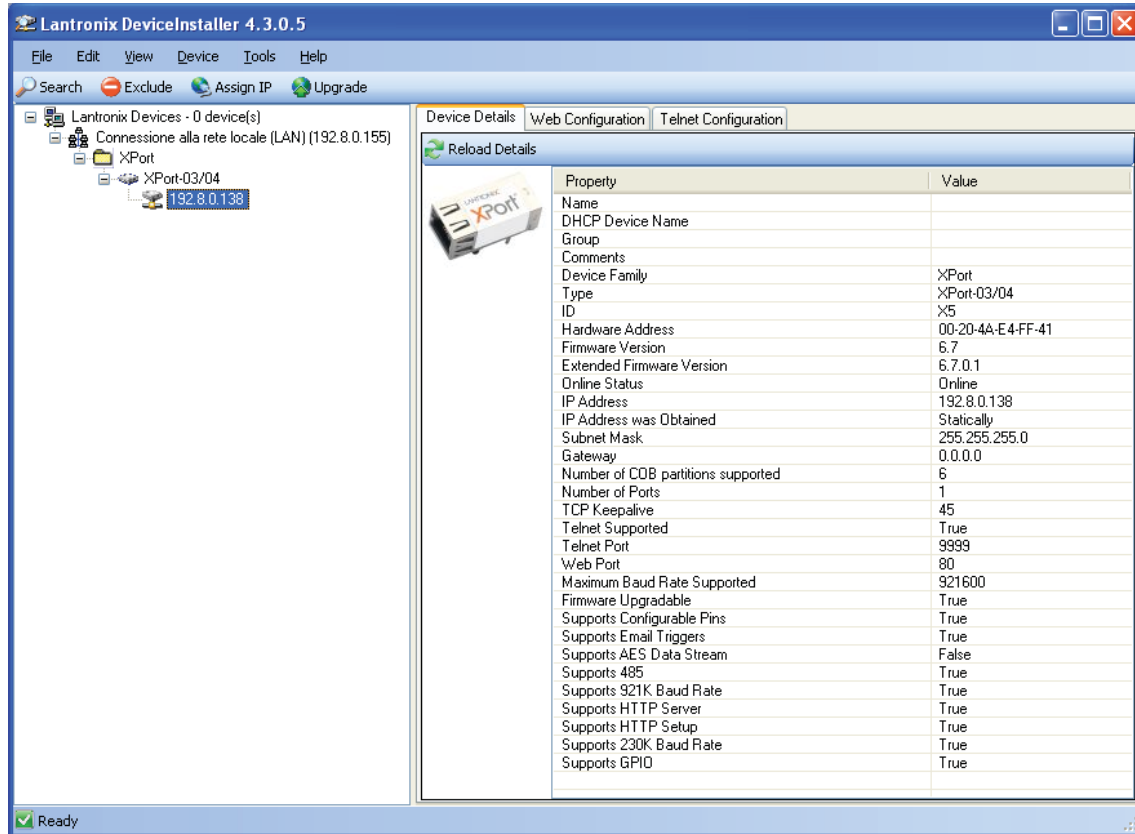

Select the found device and click on the Telnet Configuration tab. Click on Connect, and then press Enter on keyboard.

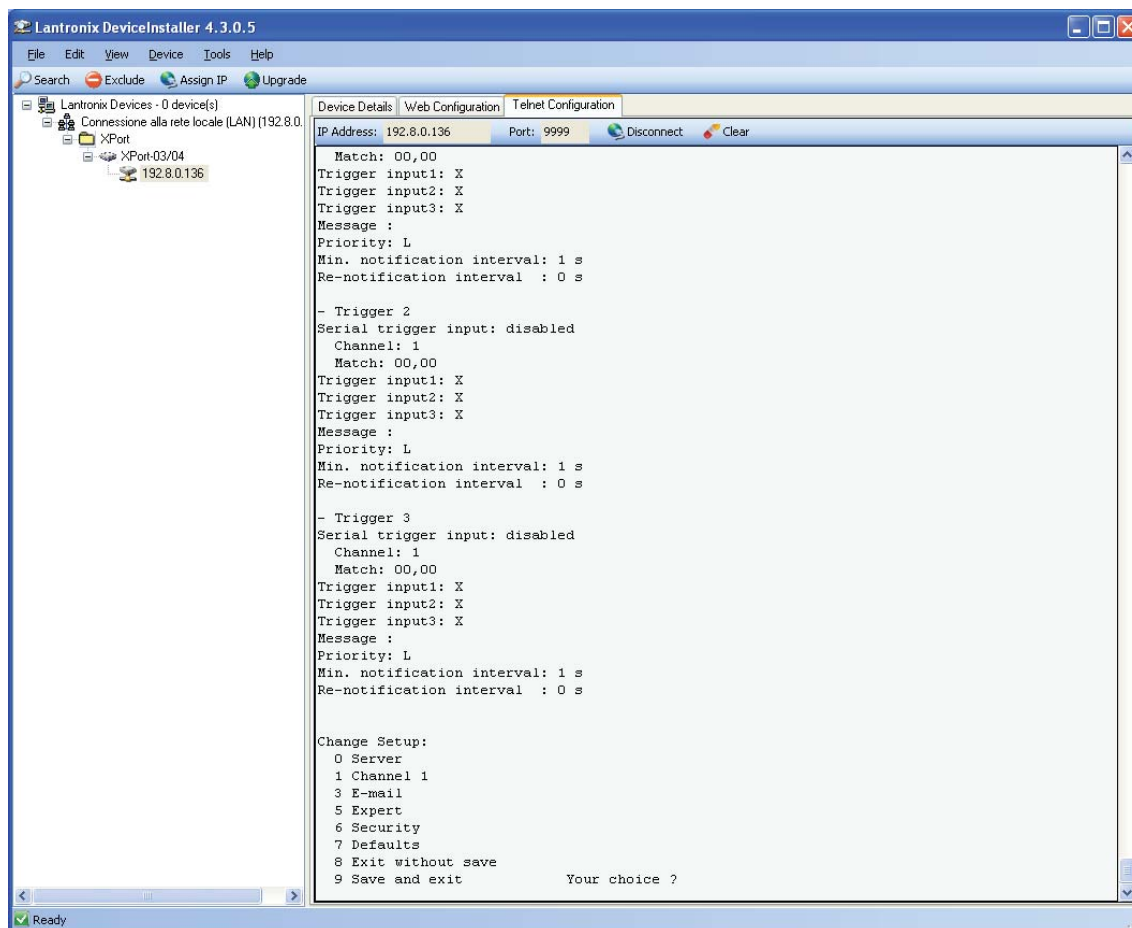

Press 0 to change server settings: change only the 4 fields of IP address and confirm the other parameters by pressing Enter. Set a static IP address.

WEBSITE

Set **UEb5ru** operation mode (into **EtHnEt** menu on the instrument) and restart the instrument to apply changes. Open your web browser and point to the instrument address to be monitored, it will open the following page:



The screenshot shows the login page of the Interface Force Measurement Solutions website. The header features the "interface" logo and "FORCE MEASUREMENT SOLUTIONS." Below the header is a red navigation bar with "Status | Settings | Supprt" on the left and "[Refresh] [Logout]" on the right. The main content area contains a login form with "Username" and "Password" fields. The "Username" field is filled with "LAUMAS". Below the fields are "Login" and "Support" buttons. The footer contains copyright information: "© Interface®, Inc. - All rights reserved - Ver. 1.0 - www.interfaceforce.com" and "S/N: 12120025 ver. 10202".

Enter the “LAUMAS” user name and the password supplied with the instrument in respective fields, then press LOGIN to enter the status page:

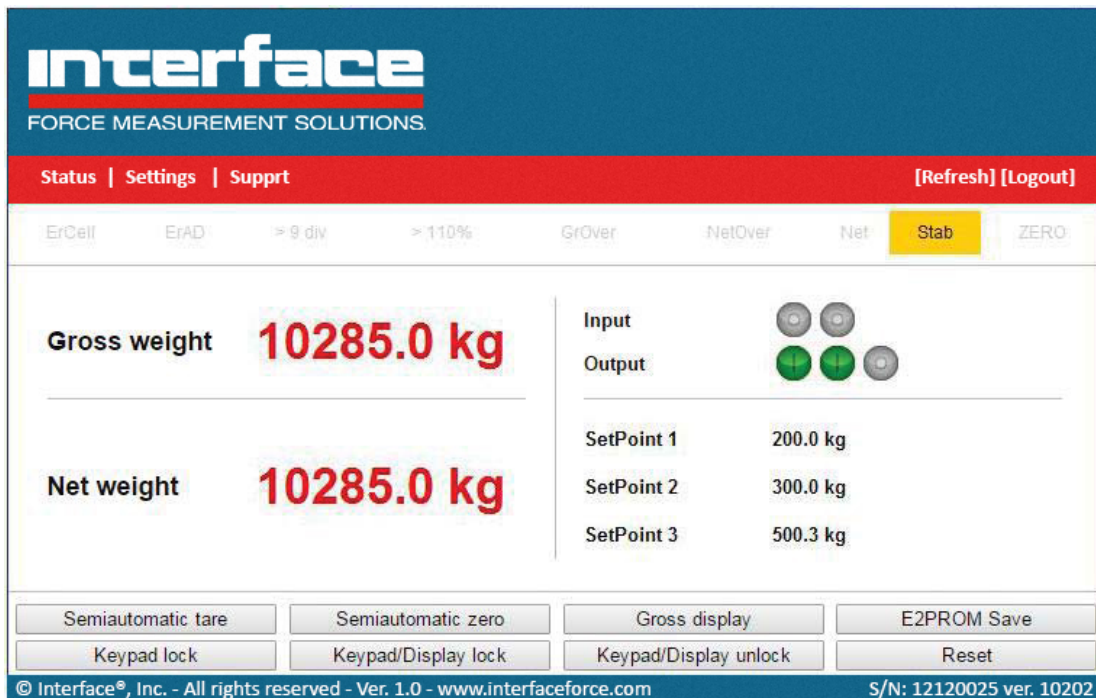

The screenshot shows the status page of the Interface Force Measurement Solutions website. The header and navigation bar are identical to the login page. The main content area displays various status indicators: "ErCell", "ErAD", "> 9 div", "> 110%", "GrOver", "NetOver", "Net", "Stab" (highlighted in yellow), and "ZERO". Below these indicators, the "Gross weight" and "Net weight" are both displayed as "10285.0 kg" in large red text. To the right, there are "Input" and "Output" status indicators represented by circles. Below these are "SetPoint 1" (200.0 kg), "SetPoint 2" (300.0 kg), and "SetPoint 3" (500.3 kg). At the bottom, there are several control buttons: "Semiautomatic tare", "Semiautomatic zero", "Gross display", "E2PROM Save", "Keypad lock", "Keypad/Display lock", "Keypad/Display unlock", and "Reset". The footer contains the same copyright information as the login page.

If there is an incorrect parameter setting, the “INSTRUMENT DATA READING ERROR” message is displayed.

The instrument status page shows the gross and net weight read, the setpoint values set and allows you to send the main commands (Tare, Zero setting, E2PROM saving, etc.). It also shows instrument status, including possible anomalies:

- ErCell** load cell error
- ErAD** instrument converter error
- >9div** weight exceeds maximum weight by 9 divisions
- >110%** weight exceeds 110% of full scale
- GrOver** gross weight over 999999
- NetOver** net weight over 999999
- Net**..... instrument shows the net weight
- Stab** weight is stable
- ZERO** weight is zero

Number of decimals and unit of measure are read by the instrument. If outputs are set in PLC mode, click on related icons to do a remote status check.

Click on Settings to enter the instrument configuration page:

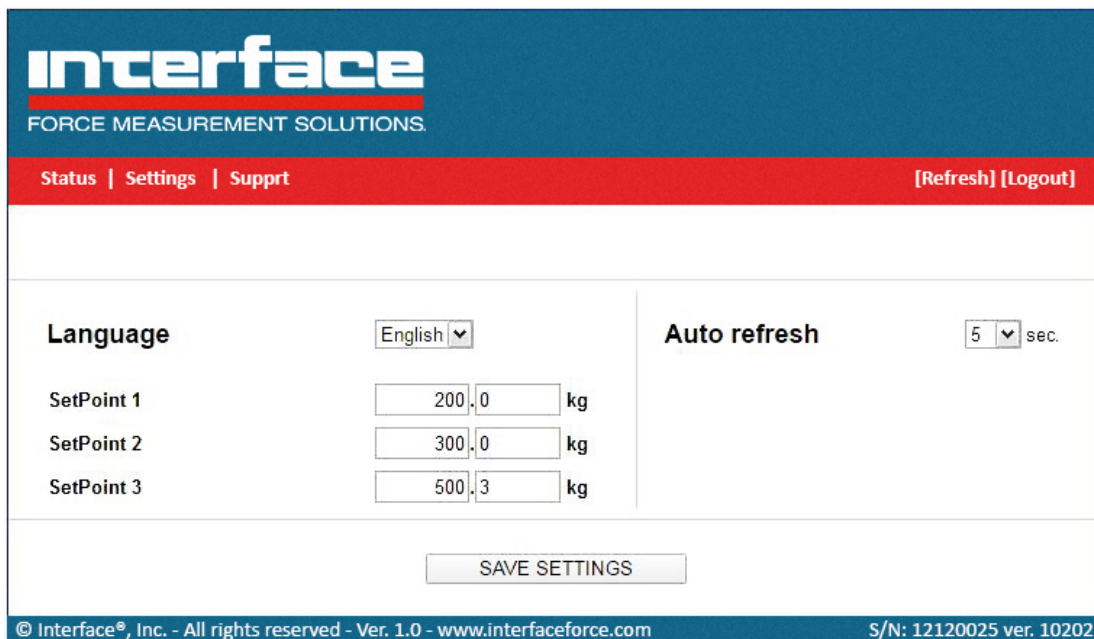

In the configuration page you can:

- set language and page refresh time: by pressing **SAVE SETTINGS** data are saved on the instrument and will be used for subsequent accesses.
- set setpoint: by pressing **SAVE SETTINGS** the new values are sent to the instrument and activated, but will be lost at instrument restart or power off; to permanently save setpoint values, press **E2PROM Save** in status page.

ETHERCAT

TECHNICAL SPECIFICATIONS

Port	2x RJ45 10Base-T or 100Base-TX (auto-detect)
-------------	--

The instrument features an ETHERCAT dual port that allows the exchange of weight and main parameters with an ETHERCAT *master*.

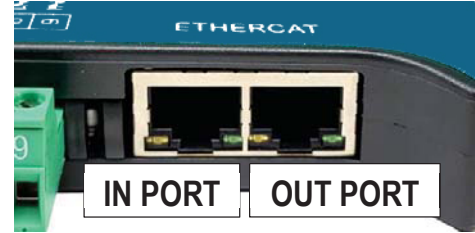

PC/PLC SETUP

The instrument works as *slave* in an ETHERCAT network.

Load the xml file attached to the instrument to the ETHERCAT *master* development system. Insert and configure the INFETHERCAT in an existing project.

The data exchanged by the instrument are:

Output Data from instrument (Reading)	Addresses
Gross Weight [4 byte]	0x0000-0x0003
Net Weight [4byte]	0x0004-0x0007
Exchange Register [4 byte]	0x0008-0x000B
Status Register [2 byte]	0x000C-0x000D
Digital Inputs status [2 byte]	0x000E-0x000F
Digital Outputs status [2 byte]	0x0010-0x0011

Input Data to instrument (Writing)	Addresses
Command Register [2 byte]	0x0000-0x0001
Digital Outputs Command [2 byte]	0x0002-0x0003
Exchange Register [4 byte]	0x0004-0x0007

GROSS WEIGHT, NET WEIGHT: the weight values are expressed as positive integer numbers, including decimal figures, but without decimal point. Read the Status Register to obtain information about sign and possible errors on the weight.

DIGITAL INPUTS STATUS

Bit 0	INPUT 1 status
Bit 1	INPUT 2 status
Bit 2	
Bit 3	
Bit 4	
Bit 5	
Bit 6	
Bit 7	

Bit = 1: high input; Bit = 0: low input

DIGITAL OUTPUTS STATUS

Bit 0	OUTPUT 1 status
Bit 1	OUTPUT 2 status
Bit 2	OUTPUT 3 status
Bit 3	
Bit 4	
Bit 5	
Bit 6	
Bit 7	

DIGITAL OUTPUTS COMMAND

Allows control of the outputs set to **PLC** mode (see **INPUT AND OUTPUT CONFIGURATION**):

Bit 0	OUTPUT 1 status	Bit 8	
Bit 1	OUTPUT 2 status	Bit 9	
Bit 2	OUTPUT 3 status	Bit 10	
Bit 3		Bit 11	
Bit 4		Bit 12	
Bit 5		Bit 13	
Bit 6		Bit 14	
Bit 7		Bit 15	Force outputs

Bit = 1: output is closed; Bit = 0: output is open



Setting bit 15 to 1 on the PLC, the master takes control of all the outputs, whatever their setting.

STATUS REGISTER

Bit 0	Load cell error	Bit 8	Net weight negative sign
Bit 1	AD converter malfunction	Bit 9	Peak weight negative sign
Bit 2	Maximum weight exceeded by 9 divisions	Bit 10	Net display mode
Bit 3	Gross weight higher than 110% of full scale	Bit 11	Weight stability
Bit 4	Gross weight beyond 999999 or less than -999999	Bit 12	Weight within $\pm\frac{1}{4}$ of a division around ZERO
Bit 5	Net weight beyond 999999 or less than -999999	Bit 13	
Bit 6		Bit 14	
Bit 7	Gross weight negative sign	Bit 15	

POSSIBLE COMMANDS TO BE SENT TO THE COMMAND REGISTER

0	No command	1	
6		7	SEMI-AUTOMATIC TARE enabling (net weight displaying)
8	SEMI-AUTOMATIC ZERO	9	SEMI-AUTOMATIC TARE disabling (gross weight displaying)
20		21	Keypad lock
22	Keypad and display unlock	23	Keypad and display lock
86		87**	Preset tare reading
88**	Preset tare writing	89	
90**	Setpoint 1 reading	91**	Setpoint 2 reading
92**	Setpoint 3 reading	93**	Setpoint 1 writing
94**	Setpoint 2 writing	95**	Setpoint 3 writing
98		99	Save data in EEPROM
100	TARE WEIGHT ZERO SETTING for calibration	101	Sample weight storage for calibration
102**	Sample Weight reading	103**	Sample Weight writing
130	Preset tare enabling	131	

***) The instrument features two Exchange Registers (one for reading and one for writing), which must be used together with the Command Register in order to access these values. These are the procedures to follow:

- READING: send the desired datum reading command (e.g.: 90 for "Setpoint 1 reading") to the Command Register and read the content of the Exchange Register.
- WRITING: write the value that you want to set in the Exchange Register and send the desired datum writing command (e.g.: 93 for "Setpoint 1 writing") to the Command Register.

If it is necessary to execute the same command twice consecutively, send command 0 between the first command and the following one.

Setpoint Reading/Writing

The setpoints are weight values expressed as positive integer numbers, include decimal figures but without decimal point.

Setpoints are stored to RAM and lost upon instrument power off; to save them in EEPROM, so that they are maintained upon instrument power on, it is necessary to send the command 99 "Save data in EEPROM" of the Command Register.

Preset tare

Write the preset tare value through the command 88 "Write preset tare". Send the command 130 "Enable preset tare" to enable the preset tare.

REAL CALIBRATION COMMANDS (WITH SAMPLE WEIGHTS)

- Unload the system and reset to zero the displayed weight value with the command 100 “TARE WEIGHT ZERO SETTING for calibration” of the Command Register.
- Load a sample weight on the system, write its value into the Exchange Register and send the command 103 “Sample Weight writing” to the Command Register;
- To save the value send the command 101 “Sample weight storage for calibration” to the Command Register.

If the operation is successfully completed, the command 102 “Sample Weight reading” returns a value equal to zero.

ETHERNET/IP

TECHNICAL SPECIFICATIONS

Port	2x RJ45 10Base-T or 100Base-TX (auto-detect)
Link led indications	off.....No link steady greenLink established
Activity led indications	off.....No activity blinking amber.....Activity detected

The instrument features an Ethernet/IP dual port that allows the exchange of weight and main parameters with an Ethernet/IP *scanner*.

INSTRUMENT SETUP

 +  → *EtHnEt*

- *SUAP* (default: *n0*): it allows to select the reading/writing of the byte in LITTLE-ENDIAN or BIG-ENDIAN mode
 - *YES*: BIG ENDIAN
 - *n0*: LITTLE ENDIAN
- *IPAddr* (default: 192.8.0.141): set instrument IP address.
- *SUBnEt* (default: 255.255.255.0): set instrument Subnet Mask.
- *GAteWAY* (default: 192.8.0.111): set Gateway address of Ethernet network.

In order to apply the changes, press  until the display shows *EtHnEt*.

PC/PLC SETUP

The instrument works as *adapter* in an Ethernet/IP network. Refer to one of the following procedures to configure the communication with the instrument:

- load the eds file attached to the instrument to the Ethernet/IP *scanner* development system.
- using a generic Ethernet/IP module, open a class 1 I/O connection with the following settings:

Settings for class 1 communication		
Assembly	Assembly Instance	Size (16-bit)
Input	101	9
Output	100	4
Configuration	128	0

- If explicit messages are used and PLC supports class 3 connections (with appropriate interface), insert the data shown on table “Settings for class 1 communication”.
- If explicit messages are used and PLC needs data read/write messages to be constructed manually, see table “Manual settings for communication”. The arrays dimensions of exchanged data are the same as those reported on table “Settings for class 1 communication” (see “size” column, Assembly “Input” and “Output” rows).

Manual settings for communication		
Field	Read	Write
Service	0x0E	0x10
Class	0x04	0x04
Instance	0x65	0x64
Attribute	0x03	0x03
Data	NO	Byte array to be written

The data exchanged by the instrument are:

Output Data from instrument (Reading)	Addresses – input assembly
Gross Weight [4 byte]	0x0000-0x0003
Net Weight [4 byte]	0x0004-0x0007
Exchange Register [4 byte]	0x0008-0x000B
Status Register [2 byte]	0x000C-0x000D
Digital Inputs status [2 byte]	0x000E-0x000F
Digital Outputs status [2 byte]	0x0010-0x0011

Input Data to instrument (Writing)	Addresses – output assembly
Command Register [2 byte]	0x0000-0x0001
Digital Outputs Command [2 byte]	0x0002-0x0003
Exchange Register [4 byte]	0x0004-0x0007

GROSS WEIGHT, NET WEIGHT: the weight values are expressed as positive integer numbers, including decimal figures, but without decimal point. Read the Status Register to obtain information about sign and possible errors on the weight.

DIGITAL INPUTS STATUS

Bit 0	INPUT 1 status
Bit 1	INPUT 2 status
Bit 2	
Bit 3	
Bit 4	
Bit 5	
Bit 6	
Bit 7	

DIGITAL OUTPUTS STATUS

Bit 0	OUTPUT 1 status
Bit 1	OUTPUT 2 status
Bit 2	OUTPUT 3 status
Bit 3	
Bit 4	
Bit 5	
Bit 6	
Bit 7	

Bit = 1: high input; Bit = 0: low input

DIGITAL OUTPUTS COMMAND

Allows control of the outputs set to **PLC** mode (see **INPUT AND OUTPUT CONFIGURATION**):

Bit 0	OUTPUT 1 status	Bit 8	
Bit 1	OUTPUT 2 status	Bit 9	
Bit 2	OUTPUT 3 status	Bit 10	
Bit 3		Bit 11	
Bit 4		Bit 12	
Bit 5		Bit 13	
Bit 6		Bit 14	
Bit 7		Bit 15	Force outputs

Bit = 1: output is closed; Bit = 0: output is open



Setting bit 15 to 1 on the PLC, the Ethernet/IP *scanner* takes control of all the outputs, whatever their setting.

STATUS REGISTER

Bit 0	Load cell error	Bit 8	Net weight negative sign
Bit 1	AD converter malfunction	Bit 9	Peak weight negative sign
Bit 2	Maximum weight exceeded by 9 divisions	Bit 10	Net display mode
Bit 3	Gross weight higher than 110% of full scale	Bit 11	Weight stability
Bit 4	Gross weight beyond 999999 or less than -999999	Bit 12	Weight within $\pm\frac{1}{4}$ of a division around ZERO
Bit 5	Net weight beyond 999999 or less than -999999	Bit 13	
Bit 6		Bit 14	
Bit 7	Gross weight negative sign	Bit 15	

POSSIBLE COMMANDS TO BE SENT TO THE COMMAND REGISTER

0	No command	1	
6		7	SEMI-AUTOMATIC TARE enabling (net weight displaying)
8	SEMI-AUTOMATIC ZERO	9	SEMI-AUTOMATIC TARE disabling (gross weight displaying)
20		21	Keypad lock
22	Keypad and display unlock	23	Keypad and display lock
86		87**	Preset tare reading
88**	Preset tare writing	89	
90**	Setpoint 1 reading	91**	Setpoint 2 reading
92**	Setpoint 3 reading	93**	Setpoint 1 writing
94**	Setpoint 2 writing	95**	Setpoint 3 writing
98		99	Save data in EEPROM
100	TARE WEIGHT ZERO SETTING for calibration	101	Sample weight storage for calibration
102**	Sample Weight reading	103**	Sample Weight writing
130	Preset tare enabling	131	

***) The instrument features two Exchange Registers (one for reading and one for writing), which must be used together with the Command Register in order to access these values. These are the procedures to follow:

- READING: send the desired datum reading command (e.g.: 90 for "Setpoint 1 reading") to the Command Register and read the content of the Exchange Register.
- WRITING: write the value that you want to set in the Exchange Register and send the desired datum writing command (e.g.: 93 for "Setpoint 1 writing") to the Command Register.

If it is necessary to execute the same command twice consecutively, send command 0 between the first command and the following one.

Setpoint Reading/Writing

The setpoint are weight values expressed as positive integer numbers, include decimal figures but without decimal point.

Setpoints are stored to RAM and lost upon instrument power off. To save them in EEPROM, so that they are maintained upon instrument power on, it is necessary to send the command 99 “Save data in EEPROM” of the Command Register.

Preset tare

Write the preset tare value through the command 88 “Write preset tare”. Send the command 130 “Enable preset tare” to enable the preset tare.

REAL CALIBRATION COMMANDS (WITH SAMPLE WEIGHTS)

- Unload the system and reset to zero the displayed weight value with the command 100 “TARE WEIGHT ZERO SETTING for calibration” of the Command Register.
- Load a sample weight on the system, write its value into the Exchange Register and send the command 103 “Sample Weight writing” to the Command Register;
- To save the value send the command 101 “Sample weight storage for calibration” to the Command Register.

If the operation is successfully completed, the command 102 “Sample Weight reading” returns a value equal to zero.

MODBUS/TCP

TECHNICAL SPECIFICATIONS

Port	RJ45 10Base-T or 100Base-TX (auto-detect)
Link led indications	off No link amber 10 Mb/s green 100 Mb/s
Activity led indications	off No activity amber Half Duplex green Full Duplex

The instrument features a Modbus/TCP port that allows the exchange of weight and main parameters with a Modbus/TCP *master*.

PC/PLC SETUP

The instrument works as *slave* in a Modbus/TCP network.

IP ADDRESS SETTING

Install the Lantronix DeviceInstaller application on a PC with Microsoft Windows operating system (run the *DEVINST.exe* file). Connect the PC to the instrument via LAN (point-to point or by hub/switch), then run the application and click on Search:

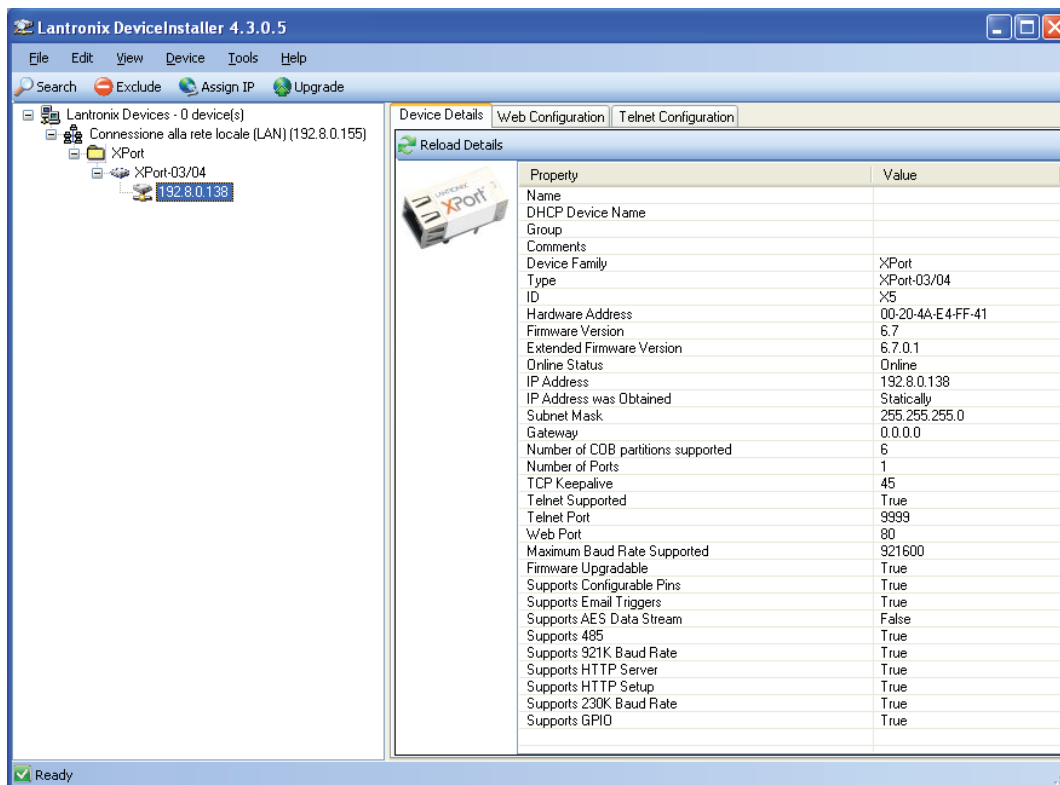

Select the device found and click on Assign IP.

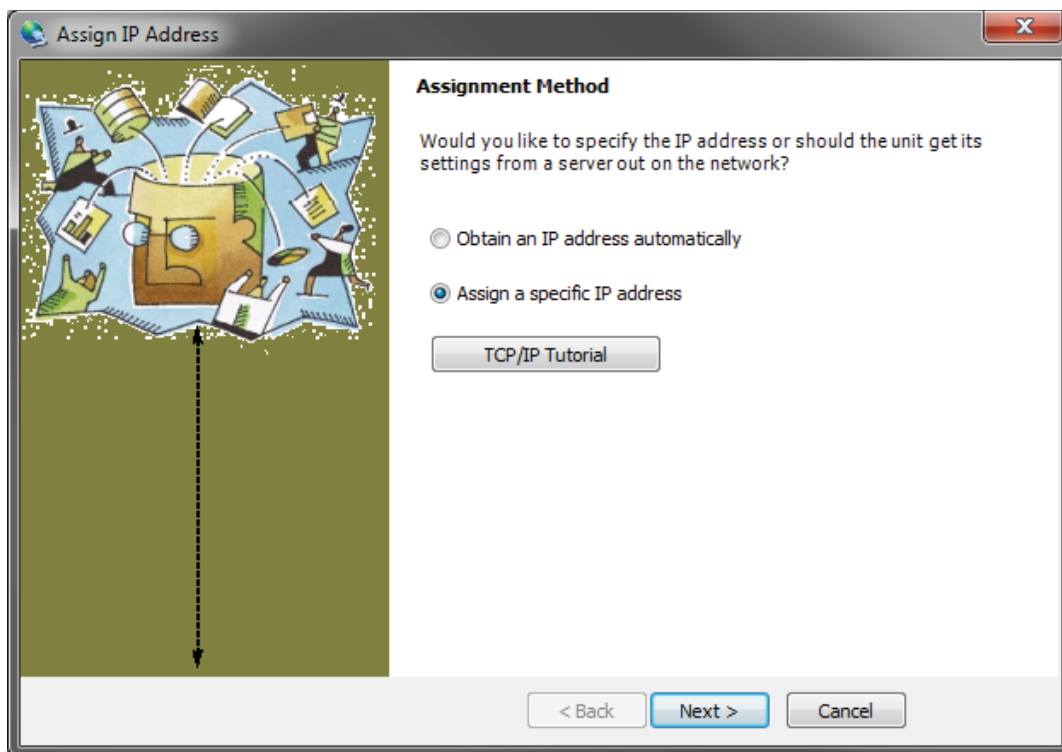

Select Assign a specific IP address, enter the desired values and click on Assign. Wait for the procedure to complete (no need to restart the instrument).

Modbus/TCP commands and registers are the same as ModbusRTU protocol: for details see **MODBUS-RTU PROTOCOL**.

POWERLINK

TECHNICAL SPECIFICATIONS

Port	2x RJ45 10Base-T or 100Base-TX (auto-detect)
Addresses	1-239

The instrument features a POWERLINK dual port that allows the exchange of weight and main parameters with a POWERLINK *controller*.

INSTRUMENT SETUP

← + ✕ E t H n E t

- n 0 d E i d (default: 1): set the instrument address

PC/PLC SETUP

The instrument works as *slave* in a POWERLINK network.
Load the xdd file attached to the instrument to the POWERLINK *master* development system. Insert and configure the INFPOWERLINK in an existing project.
The data exchanged by the instrument are:

Output Data from instrument (Reading)	Addresses
Gross Weight [4 byte]	0x0000-0x0003
Net Weight [4byte]	0x0004-0x0007
Exchange Register [4 byte]	0x0008-0x000B
Status Register [2 byte]	0x000C-0x000D
Digital Inputs status [2 byte]	0x000E-0x000F
Digital Outputs status [2 byte]	0x0010-0x0011

Input Data to instrument (Writing)	Addresses
Command Register [2 byte]	0x0000-0x0001
Digital Outputs Command [2 byte]	0x0002-0x0003
Exchange Register [4 byte]	0x0004-0x0007

GROSS WEIGHT, NET WEIGHT: the weight values are expressed as positive integer numbers, including decimal figures, but without decimal point. Read the Status Register to obtain information about sign and possible errors on the weight.

DIGITAL INPUTS STATUS

Bit 0	INPUT 1 status
Bit 1	INPUT 2 status
Bit 2	
Bit 3	
Bit 4	
Bit 5	
Bit 6	
Bit 7	

Bit = 1: high input; Bit = 0: low input

DIGITAL OUTPUTS STATUS

Bit 0	OUTPUT 1 status
Bit 1	OUTPUT 2 status
Bit 2	OUTPUT 3 status
Bit 3	
Bit 4	
Bit 5	
Bit 6	
Bit 7	

DIGITAL OUTPUT COMMANDS

Allows control of the outputs set to **PLC** mode (see **INPUT AND OUTPUT CONFIGURATION**):

Bit 0	OUTPUT 1 status	Bit 8	
Bit 1	OUTPUT 2 status	Bit 9	
Bit 2	OUTPUT 3 status	Bit 10	
Bit 3		Bit 11	
Bit 4		Bit 12	
Bit 5		Bit 13	
Bit 6		Bit 14	
Bit 7		Bit 15	Force outputs

Bit = 1: output is closed; Bit = 0: output is open



Setting bit 15 to 1 on the PLC, the master takes control of all the outputs, whatever their setting.

STATUS REGISTER

Bit 0	Load cell error	Bit 8	Net weight negative sign
Bit 1	AD converter malfunction	Bit 9	Peak weight negative sign
Bit 2	Maximum weight exceeded by 9 divisions	Bit 10	Net display mode
Bit 3	Gross weight higher than 110% of full scale	Bit 11	Weight stability
Bit 4	Gross weight beyond 999999 or less than -999999	Bit 12	Weight within $\pm\frac{1}{4}$ of a division around ZERO
Bit 5	Net weight beyond 999999 or less than -999999	Bit 13	
Bit 6		Bit 14	
Bit 7	Gross weight negative sign	Bit 15	

POSSIBLE COMMANDS TO BE SENT TO THE COMMAND REGISTER

0	No command	1	
6		7	SEMI-AUTOMATIC TARE enabling (net weight displaying)
8	SEMI-AUTOMATIC ZERO	9	SEMI-AUTOMATIC TARE disabling (gross weight displaying)
20		21	Keypad lock
22	Keypad and display unlock	23	Keypad and display lock
86		87**	Preset tare reading
88**	Preset tare writing	89	
90**	Setpoint 1 reading	91**	Setpoint 2 reading
92**	Setpoint 3 reading	93**	Setpoint 1 writing
94**	Setpoint 2 writing	95**	Setpoint 3 writing
98		99	Save data in EEPROM
100	TARE WEIGHT ZERO SETTING for calibration	101	Sample weight storage for calibration
102**	Sample Weight reading	103**	Sample Weight writing
130	Preset tare enabling	131	

**) The instrument features two Exchange Registers (one for reading and one for writing), which must be used together with the Command Register in order to access these values. These are the procedures to follow:

- READING: send the desired datum reading command (e.g.: 90 for "Setpoint 1 reading") to the Command Register and read the content of the Exchange Register.
- WRITING: write the value that you want to set in the Exchange Register and send the desired datum writing command (e.g.: 93 for "Setpoint 1 writing") to the Command Register.

If it is necessary to execute the same command twice consecutively, send command 0 between the first command and the following one.

Setpoint Reading/Writing

The setpoints are weight values expressed as positive integer numbers, include decimal figures but without decimal point.

Setpoints are stored to RAM and lost upon instrument power off; to save them in EEPROM, so that they are maintained upon instrument power on, it is necessary to send the command 99 "Save data in EEPROM" of the Command Register.

Preset tare

Write the preset tare value through the command 88 "Write preset tare". Send the command 130 "Enable preset tare" to enable the preset tare.

REAL CALIBRATION COMMANDS (WITH SAMPLE WEIGHTS)

- Unload the system and reset to zero the displayed weight value with the command 100 “TARE WEIGHT ZERO SETTING for calibration” of the Command Register.
- Load a sample weight on the system, write its value into the Exchange Register and send the command 103 “Sample Weight writing” to the Command Register;
- To save the value send the command 101 “Sample weight storage for calibration” to the Command Register.

If the operation is successfully completed, the command 102 “Sample Weight reading” returns a value equal to zero.

PROFIBUS-DP

TECHNICAL SPECIFICATIONS

Baud rate	Up to 12 Mb/s
Addresses	1-99
Profibus status led indications	slow blinkingProfibus error fast blinking..... Profibus OK

It is necessary to activate the termination resistance on the two devices located at the ends of the network.

The instrument features a Profibus-DP port that allows the exchange of weight and main parameters with a Profibus-DP *master*.

INSTRUMENT SETUP

 +  PrDFI

- *Addr* (default: 1): set the instrument address in the Profibus network

In order to apply the changes, turn the instrument off, wait for 10 seconds and turn it back on.

PC/PLC SETUP

The instrument works as *slave* in a Profibus-DP network.

Load the gsd file attached to the instrument to the Profibus-DP development system.

Insert and configure the INFPROFIBUS in an existing project.

Usable software modules are:

NAME	DESCRIPTION	R/W	SIZE
Gross Weight	Gross weight	R	4 byte
Net Weight	Net weight	R	4 byte
Peak Weight	Peak weight	R	4 byte
Setpoint 1	Setpoint 1	R/W*	4 byte / 4 byte
Setpoint 2	Setpoint 2	R/W*	4 byte / 4 byte
Setpoint 3	Setpoint 3	R/W*	4 byte / 4 byte
Hysteresis 1	Setpoint 1 hysteresis	R/W*	4 byte / 4 byte
Hysteresis 2	Setpoint 2 hysteresis	R/W*	4 byte / 4 byte
Hysteresis 3	Setpoint 3 hysteresis	R/W*	4 byte / 4 byte
Division	Divisions	R	2 byte
Unit	Units of measure	R	2 byte

Visualization Coefficient	Display coefficient	R	4 byte
Inputs	Inputs status	R	2 byte
Outputs	Outputs status	R/W	2 byte / 2 byte
Status Register	Status register	R	2 byte
Command Register	Command register	W	2 byte
Sample Weight	Sample weight	R/W*	4 byte / 4 byte

*) 0x00000000 value in writing is ignored. To reset the value, write out 0x80000000.

GROSS WEIGHT, NET WEIGHT, PEAK WEIGHT: the weight values are expressed as positive integer numbers, including decimal figures, but without decimal point. Read the Status Register to obtain information about sign and possible errors in the weight. To find out the decimal figures, use the Division module. **Example:** If the read net weight is 100000 and the scale verification division (e) is 0.001, the real weight value is 100.000 kg.

SETPOINT, HYSTERESIS: the weight values are expressed as positive integer numbers, including decimal figures, but without decimal point.

- To set 0, write the conventional hexadecimal value hex 80000000 to the register (the most significant bit set to 1 and the other to 0).
- To set the values correctly use the Division module; example: if you want to set a setpoint to 100 kg and the scale verification division (e) is 0.001, set the setpoint value to 100000 (weight value with three decimals but without decimal point).
- If from PLC you set a value out of the permitted interval (from 0, not included, to full scale) the value is ignored and the bit 13 "Writing error" rises in the Status Register.

The setpoints are stored to RAM and lost upon instrument power off. To save them in EEPROM so that they are maintained upon instrument power on, it is necessary to send the command 99 "Save data in EEPROM" of the Command Register.

DIVISION

The value of the register read by Profibus corresponds to the division of the instrument (parameter *dl U1 5*).

Division value	Divisor	Decimals
0	100	0
1	50	0
2	20	0
3	10	0
4	5	0
5	2	0
6	1	0
7	0.5	1
8	0.2	1
9	0.1	1
10	0.05	2
11	0.02	2
12	0.01	2
13	0.005	3
14	0.002	3
15	0.001	3
16	0.0005	4
17	0.0002	4
18	0.0001	4

UNITS OF MEASURE

The value of the register read by Profibus corresponds to the unit of measure used by the instrument (parameter *U1 1*).

Unit of measure value	Unit of measure description	Coefficient effect on the read gross weight
0	Kilograms	No effect
1	Grams	No effect
2	Tons	No effect
3	Pounds	No effect
4	Newton	Multiplies
5	Litres	Divides
6	Bar	Multiplies
7	Atmospheres	Multiplies
8	Pieces	Divides
9	Newton Metres	Multiplies
10	Kilogram Metres	Multiplies
11	Other	Multiplies

DISPLAY COEFFICIENT: contains the *COEFF* parameter value expressed as integer number, with four decimal figures, but without decimal point.

Example: if the module contains 12000, the *COEFF* parameter value is 1.2000.

DIGITAL INPUTS STATUS

Bit 0	INPUT 1 status
Bit 1	INPUT 2 status
Bit 2	
Bit 3	
Bit 4	
Bit 5	
Bit 6	
Bit 7	

Bit = 1: high input; Bit = 0: low input

DIGITAL OUTPUTS STATUS

Bit 0	OUTPUT 1 status
Bit 1	OUTPUT 2 status
Bit 2	OUTPUT 3 status
Bit 3	
Bit 4	
Bit 5	
Bit 6	
Bit 7	

DIGITAL OUTPUTS COMMAND

Allows control of the outputs set to *PLC* mode (see **INPUT AND OUTPUT CONFIGURATION**):

Bit 0	OUTPUT 1 status	Bit 8	
Bit 1	OUTPUT 2 status	Bit 9	
Bit 2	OUTPUT 3 status	Bit 10	
Bit 3		Bit 11	
Bit 4		Bit 12	
Bit 5		Bit 13	
Bit 6		Bit 14	
Bit 7		Bit 15	Force outputs

Bit = 1: output is closed; Bit = 0: output is open



Setting bit 15 to 1 on the PLC, the master takes control of all the outputs, whatever their setting.

STATUS REGISTER

Bit 0	Load cell error	Bit 8	Net weight negative sign
Bit 1	AD converter malfunction	Bit 9	Peak weight negative sign
Bit 2	Maximum weight exceeded by 9 divisions	Bit 10	Net display mode
Bit 3	Gross weight higher than 110% of full scale	Bit 11	Weight stability
Bit 4	Gross weight beyond 999999 or less than -999999	Bit 12	Weight within $\pm\frac{1}{4}$ of a division around ZERO
Bit 5	Net weight beyond 999999 or less than -999999	Bit 13	Writing error
Bit 6		Bit 14	
Bit 7	Gross weight negative sign	Bit 15	

POSSIBLE COMMANDS TO BE SENT TO THE COMMAND REGISTER

0	No command	1	
6		7	SEMI-AUTOMATIC TARE enabling (net weight displaying)
8	SEMI-AUTOMATIC ZERO	9	SEMI-AUTOMATIC TARE disabling (gross weight displaying)
20		21	Keypad lock
22	Keypad and display unlock	23	Keypad and display lock
98		99	Save data in EEPROM
100	TARE WEIGHT ZERO SETTING for calibration	101	Sample weight storage for calibration

If it is necessary to execute the same command twice consecutively, send command 0 between the first command and the following one.

REAL CALIBRATION COMMANDS (WITH SAMPLE WEIGHTS)

- Unload the system and reset to zero the displayed weight value with the command 100 “TARE WEIGHT ZERO SETTING for calibration” of the Command Register.
- Load a sample weight on the system and send its value to the “Sample weight” module.
- Send zero to the “Sample weight” module.
- To save the value send the command 101 “Sample weight storage for calibration” to the Command Register.

If the operation is successfully completed, the sample weight read is set to zero.

PROFINET-IO

TECHNICAL SPECIFICATIONS

Port	2x RJ45 100Base-TX
Link led indications	off.....No link steady greenLink established
Activity led indications	off.....No activity blinking amber.....Activity detected

The instrument features a Profinet-IO dual port that allows the exchange of weight and main parameters with a Profinet-IO *controller*.

INSTRUMENT SETUP

 +  → *EtHnEt*

- **SUAP** (default: *n0*): it allows to select the reading/writing of the byte in LITTLE-ENDIAN or BIG-ENDIAN mode
 - **YES**: LITTLE ENDIAN
 - **n0**: BIG ENDIAN

PC/PLC SETUP

The instrument works as *device* in a Profinet-IO network.

Load the gsdml file attached to the instrument to the Profinet-IO *controller* development system. Insert and configure the INFPROFINETIO in an existing project.

Assign a name to the device (function *Assign Device Name*) using the following characters: lower case letters (a-z), numbers (0-9), minus character (-).

Set at least 8 ms as Profinet's I/O refresh time.

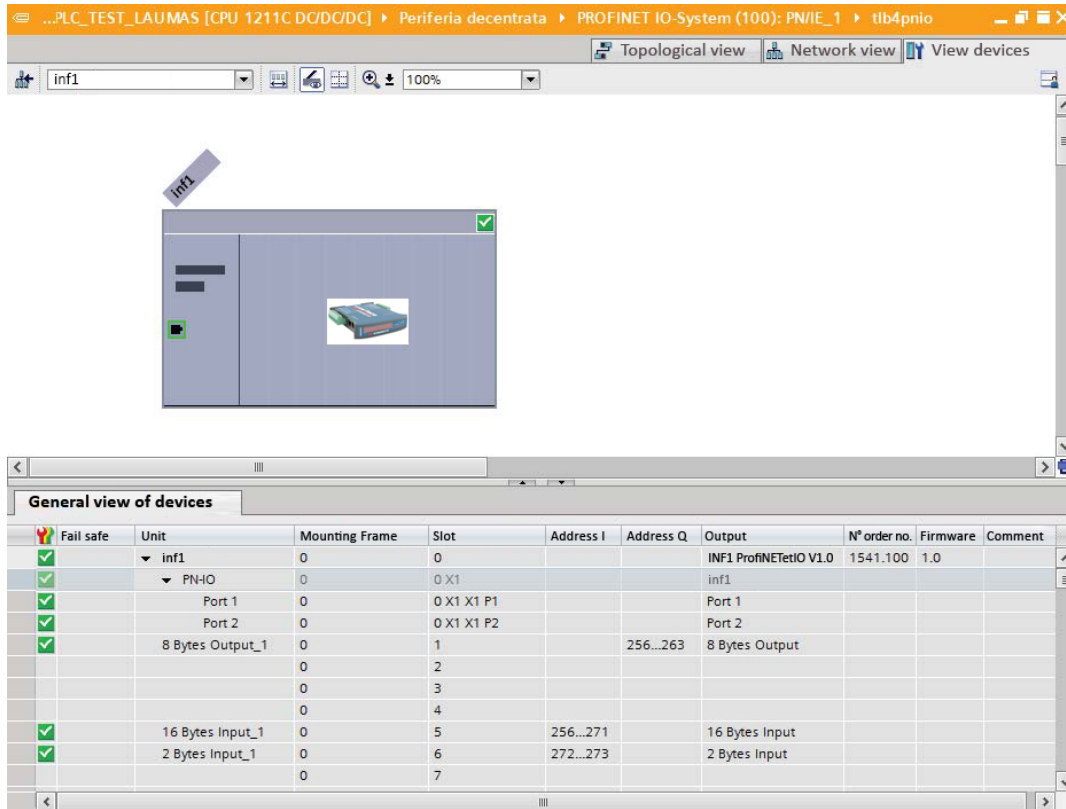

The data exchanged by the instrument are:

Output Data from instrument (Reading)	Addresses	Type
Gross Weight [4 byte]	0x0000-0x0003	16 byte input
Net Weight [4 byte]	0x0004-0x0007	
Exchange Register [4 byte]	0x0008-0x000B	
Status Register [2 byte]	0x000C-0x000D	
Digital Inputs status [2 byte]	0x000E-0x000F	
Digital Outputs status [2 byte]	0x0010-0x0011	2 byte input

Input Data to instrument (Writing)	Addresses	Type
Command Register [2 byte]	0x0000-0x0001	8 byte output
Digital Outputs Command [2 byte]	0x0002-0x0003	
Exchange Register [4 byte]	0x0004-0x0007	

GROSS WEIGHT, NET WEIGHT: the weight values are expressed as positive integer numbers, including decimal figures, but without decimal point. Read the Status Register to obtain information about sign and possible errors on the weight.

DIGITAL INPUTS STATUS

Bit 0	INPUT 1 status
Bit 1	INPUT 2 status
Bit 2	
Bit 3	
Bit 4	
Bit 5	
Bit 6	
Bit 7	

DIGITAL OUTPUTS STATUS

Bit 0	OUTPUT 1 status
Bit 1	OUTPUT 2 status
Bit 2	OUTPUT 3 status
Bit 3	
Bit 4	
Bit 5	
Bit 6	
Bit 7	

Bit = 1: high input; Bit = 0: low input

DIGITAL OUTPUT COMMANDS

Allows control of the outputs set to **PLC** mode (see **INPUT AND OUTPUT CONFIGURATION**):

Bit 0	OUTPUT 1 status	Bit 8	
Bit 1	OUTPUT 2 status	Bit 9	
Bit 2	OUTPUT 3 status	Bit 10	
Bit 3		Bit 11	
Bit 4		Bit 12	
Bit 5		Bit 13	
Bit 6		Bit 14	
Bit 7		Bit 15	Force outputs

Bit = 1: output is closed; Bit = 0: output is open



Setting bit 15 to 1 on the PLC, the master takes control of all the outputs, whatever their setting.

STATUS REGISTER

Bit 0	Load cell error	Bit 8	Net weight negative sign
Bit 1	AD converter malfunction	Bit 9	Peak weight negative sign
Bit 2	Maximum weight exceeded by 9 divisions	Bit 10	Net display mode
Bit 3	Gross weight higher than 110% of full scale	Bit 11	Weight stability
Bit 4	Gross weight beyond 999999 or less than -999999	Bit 12	Weight within $\pm\frac{1}{4}$ of a division around ZERO
Bit 5	Net weight beyond 999999 or less than -999999	Bit 13	
Bit 6		Bit 14	
Bit 7	Gross weight negative sign	Bit 15	

POSSIBLE COMMANDS TO BE SENT TO THE COMMAND REGISTER

0	No command	1	
6		7	SEMI-AUTOMATIC TARE enabling (net weight displaying)
8	SEMI-AUTOMATIC ZERO	9	SEMI-AUTOMATIC TARE disabling (gross weight displaying)
20		21	Keypad lock
22	Keypad and display unlock	23	Keypad and display lock
86		87**	Preset tare reading
88**	Preset tare writing	89	
90**	Setpoint 1 reading	91**	Setpoint 2 reading
92**	Setpoint 3 reading	93**	Setpoint 1 writing
94**	Setpoint 2 writing	95**	Setpoint 3 writing
98		99	Save data in EEPROM
100	TARE WEIGHT ZERO SETTING for calibration	101	Sample weight storage for calibration
102**	Sample Weight reading	103**	Sample Weight writing
130	Preset tare enabling	131	

***) The instrument features two Exchange Registers (one for reading and one for writing), which must be used together with the Command Register in order to access these values. These are the procedures to follow:

- **READING:** send the desired datum reading command (e.g.: 90 for "Setpoint 1 reading") to the Command Register and read the content of the Exchange Register.
- **WRITING:** write the value that you want to set in the Exchange Register and send the desired datum writing command (e.g.: 93 for "Setpoint 1 writing") to the Command Register.

If it is necessary to execute the same command twice consecutively, send command 0 between the first command and the following one.

Setpoint Reading/Writing

The setpoints are weight values expressed as positive integer numbers, include decimal figures but without decimal point.

Setpoints are stored to RAM and lost upon instrument power off. To save them in EEPROM, so that they are maintained upon instrument power on, it is necessary to send the command 99 “Save data in EEPROM” of the Command Register.

Preset tare

Write the preset tare value through the command 88 “Write preset tare”. Send the command 130 “Enable preset tare” to enable the preset tare.

REAL CALIBRATION COMMANDS (WITH SAMPLE WEIGHTS)

- Unload the system and reset to zero the displayed weight value with the command 100 “TARE WEIGHT ZERO SETTING for calibration” of the Command Register.
- Load a sample weight on the system, write its value into the Exchange Register and send the command 103 “Sample Weight writing” to the Command Register;
- To save the value send the command 101 “Sample weight storage for calibration” to the Command Register.

If the operation is successfully completed, the command 102 “Sample Weight reading” returns a value equal to zero.

SERCOSIII

TECHNICAL SPECIFICATIONS

Port	2x RJ45 10Base-T or 100Base-TX (auto-detect)
Addresses	0÷511

The instrument features a SERCOSIII dual port that allows the exchange of weight and main parameters with a SERCOSIII *master*.

INSTRUMENT SETUP



- *Addr* (default: 1): set the instrument address

PC/PLC SETUP

The instrument works as *slave* in a SERCOSIII network.
Load the *sddml* file attached to the instrument to the SERCOSIII *master* development system. Insert and configure the INFSERCOSIII in an existing project.
The data exchanged by the instrument are:

Output Data from instrument (Reading)	Addresses
AT Connection Control [2 byte]	0x0000-0x0001
AT IO Status [2 byte]	0x0002-0x0003
Gross Weight [4 byte]	0x0004-0x0007
Net Weight [4byte]	0x0008-0x000B
Exchange Register [4 byte]	0x000C-0x000F
Status Register [2 byte]	0x0010-0x0011
Digital Inputs status [2 byte]	0x0012-0x0013
Digital Outputs status [2 byte]	0x0014-0x0015

Input Data to instrument (Writing)	Addresses
MDT Connection Control [2 byte]	0x0000-0x0001
MDT IO Control [2 byte]	0x0002-0x0003
Command Register [2 byte]	0x0004-0x0005
Digital Outputs Command [2 byte]	0x0006-0x0007
Exchange Register [4 byte]	0x0008-0x000B

AT Connection Control, **AT IO Status**, **MDT Connection Control** and **MDT IO Control** are registers used by the SERCOSIII *master* to manage the communication.

GROSS WEIGHT, NET WEIGHT: the weight values are expressed as positive integer numbers, including decimal figures, but without decimal point. Read the Status Register to obtain information about sign and possible errors on the weight.

DIGITAL INPUTS STATUS

Bit 0	INPUT 1 status
Bit 1	INPUT 2 status
Bit 2	
Bit 3	
Bit 4	
Bit 5	
Bit 6	
Bit 7	

Bit = 1: high input; Bit = 0: low input

DIGITAL OUTPUTS STATUS

Bit 0	OUTPUT 1 status
Bit 1	OUTPUT 2 status
Bit 2	OUTPUT 3 status
Bit 3	
Bit 4	
Bit 5	
Bit 6	
Bit 7	

DIGITAL OUTPUT COMMANDS

Allows control of the outputs, set to **PLC** mode (see **INPUT AND OUTPUT CONFIGURATION**):

Bit 0	OUTPUT 1 status	Bit 8	
Bit 1	OUTPUT 2 status	Bit 9	
Bit 2	OUTPUT 3 status	Bit 10	
Bit 3		Bit 11	
Bit 4		Bit 12	
Bit 5		Bit 13	
Bit 6		Bit 14	
Bit 7		Bit 15	Force outputs

Bit = 1: output is closed; Bit = 0: output is open



Setting bit 15 to 1 on the PLC, the master takes control of all the outputs, whatever their setting.

STATUS REGISTER

Bit 0	Load cell error	Bit 8	Net weight negative sign
Bit 1	AD converter malfunction	Bit 9	Peak weight negative sign
Bit 2	Maximum weight exceeded by 9 divisions	Bit 10	Net display mode
Bit 3	Gross weight higher than 110% of full scale	Bit 11	Weight stability
Bit 4	Gross weight beyond 999999 or less than -999999	Bit 12	Weight within $\pm\frac{1}{4}$ of a division around ZERO
Bit 5	Net weight beyond 999999 or less than -999999	Bit 13	
Bit 6		Bit 14	
Bit 7	Gross weight negative sign	Bit 15	

POSSIBLE COMMANDS TO BE SENT TO THE COMMAND REGISTER

0	No command	1	
6		7	SEMI-AUTOMATIC TARE enabling (net weight displaying)
8	SEMI-AUTOMATIC ZERO	9	SEMI-AUTOMATIC TARE disabling (gross weight displaying)
20		21	Keypad lock
22	Keypad and display unlock	23	Keypad and display lock
86		87**	Preset tare reading
88**	Preset tare writing	89	
90**	Setpoint 1 reading	91**	Setpoint 2 reading
92**	Setpoint 3 reading	93**	Setpoint 1 writing
94**	Setpoint 2 writing	95**	Setpoint 3 writing
98		99	Save data in EEPROM
100	TARE WEIGHT ZERO SETTING for calibration	101	Sample weight storage for calibration
102**	Sample Weight reading	103**	Sample Weight writing
130	Preset tare enabling	131	

***) The instrument features two Exchange Registers (one for reading and one for writing), which must be used together with the Command Register in order to access these values. These are the procedures to follow:

- READING: send the desired datum reading command (e.g.: 90 for "Setpoint 1 reading") to the Command Register and read the content of the Exchange Register.
- WRITING: write the value that you want to set in the Exchange Register and send the desired datum writing command (e.g.: 93 for "Setpoint 1 writing") to the Command Register.

If it is necessary to execute the same command twice consecutively, send command 0 between the first command and the following one.

Setpoint Reading/Writing

The setpoints are weight values expressed as positive integer numbers, include decimal figures but without decimal point.

Setpoints are stored to RAM and lost upon instrument power off. To save them in EEPROM, so that they are maintained upon instrument power on, it is necessary to send the command 99 “Save data in EEPROM” of the Command Register.

Preset tare

Write the preset tare value through the command 88 “Write preset tare”. Send the command 130 “Enable preset tare” to enable the preset tare.

REAL CALIBRATION COMMANDS (WITH SAMPLE WEIGHTS)

- Unload the system and reset to zero the displayed weight value with the command 100 “TARE WEIGHT ZERO SETTING for calibration” of the Command Register.
- Load a sample weight on the system, write its value into the Exchange Register and send the command 103 “Sample Weight writing” to the Command Register;
- To save the value send the command 101 “Sample weight storage for calibration” to the Command Register.

If the operation is successfully completed, the command 102 “Sample Weight reading” returns a value equal to zero.

RESERVED FOR THE INSTALLER

MENU LOCKING

Through this procedure, it's possible to block access to any menu on the instrument. Select the menu that you wish to lock:

`000000` ← `CALIB` press **X** ◀ ▲ simultaneously for 3 seconds, `C.ALIB` will be shown on the display (the left point on the text indicates that this menu item is now locked). If the operator tries to enter this menu, access is denied and the display shows `BLCK`.

MENU UNLOCKING

`000000` ← `C.ALIB` press ◀ ◀ ▲ simultaneously for 3 seconds, the display shows `CALIB` (the left point on the text is off to indicate that this menu item is unlocked).

TEMPORARY MENU UNLOCKING

`000000` ← `C.ALIB` press ▲ and ◀ simultaneously for 3 seconds: it is now possible to enter and modify all menus including those which are locked. By returning to the weight display, the menu lock is restored.

DATA DELETION AND PROGRAM SELECTION

WARNING: this operation must only be performed after contacting technical support. By pressing **X** the procedure is cancelled and no changes are made.

Upon instrument power-on hold down the **X** key until the display shows **PrOG**, then proceed as follows:

CONSTANTS RESTORE (does not erase the calibration): confirm **PrOG**, use arrow keys to select **PASSU**, set code **6935** and confirm.

PROGRAM SELECTION: confirm **PrOG** and use the arrow keys to select the desired program:

bASE: basic program, setpoint management only.

rEUEr: to be used when the loaded weighing system corresponds to unloaded cells and vice versa (product increases while weight on load cells actually decreases).

After confirming the choice of the program (except **rEUEr**), the user must choose its approval status among the following possible choices:

nOLEG: not approved program;

LEGAL: approved program, single interval (Dir. 2014/31/EU, art. 1)*;

PLU-L: approved program, multi-interval (Dir. 2014/31/EU, art. 1)*;

By confirming, the instrument is restored to default and data is erased.

KEYPAD OR DISPLAY LOCKING

Press **X** immediately followed by **▲** and hold them down for about 5 seconds (this operation is also possible via the MODBUS and ASCII protocols):

- **FrEE:** no lock.
- **HEY:** keypad lock: if active, when a key is pressed the message **bLOC** is displayed for 3 seconds.
- **dI SP:** keypad and display lock: if active, the keypad is locked and the display shows the instrument model (weight is not displayed), by pressing a key the display shows **bLOC** for 3 seconds.

Warranty

Warranty

All indicator products from Interface Inc., ('Interface') are warranted against defective material and workmanship for a period of (1) one year from the date of dispatch. If the 'Interface' product you purchase appears to have a defect in material or workmanship or fails during normal use within the period, please contact your Distributor, who will assist you in resolving the problem. If it is necessary to return the product to 'Interface' please include a note stating name, company, address, phone number and a detailed description of the problem. Also, please indicate if it is a warranty repair. The sender is responsible for shipping charges, freight insurance and proper packaging to prevent breakage in transit. 'Interface' warranty does not apply to defects resulting from action of the buyer such as mishandling, improper interfacing, operation outside of design limits, improper repair or unauthorised modification. No other warranties are expressed or implied. 'Interface' specifically disclaims any implied warranties of merchantability or fitness for a specific purpose. The remedies outlined above are the buyer's only remedies. 'Interface' will not be liable for direct, indirect, special, incidental or consequential damages whether based on the contract, tort or other legal theory. Any corrective maintenance required after the warranty period should be performed by 'Interface' approved personnel only

www.interfaceforce.com