

FEATURES & BENEFITS

- Proprietary Interface temperature compensated strain gages - Capacities: 13, 33, 67 N
- 0.01% non-repeatability
- 400% compression overload protection
- 0.0015% / °C temp. effect on output
- Eccentric load compensated
- Space saving narrow housing per DIN EN 50022

SPECIFICATIONS

ACCURACY – (MAX ERROR)				
Nonlinearity – %FS		±0.02		
Hysteresis – %FS		±0.02		
Nonrepeatability – %RO		±0.01		
Creep, in 20 min – %		±0.025		
Eccentric Load Sensitivity – % / in		0.012		
TEMPERATURE				
Compensated Range	°F	+15 to +115		
	°C	-10 to +45		
Operating Range	°F	-65 to +200		
	°C	-55 to +90		
Effect on Output – % / deg	°F	±0.0008		
Effect on Zero – %RO / deg	°F	±0.0015		
ELECTRICAL				
Rated Output – mV/V (Nominal)		3.0		
Zero Balance – %RO		±5.0		
Bridge Resistance – Ohm (Nominal)		350		
Excitation Voltage – MAX VDC		15		
Insulation Resistance – Megohm		5000		
MECHANICAL				
Calibration		Comp.		
Safe Overload – %CAP		400		
NATURAL FREQUENCY/DEFLECTION				
lbf	N	Deflection		Nat. Freq. – Hertz
		in	mm	
3	13.3	0.015	0.38	130
7.5	33.4	0.009	0.23	220
15	66.7	0.009	0.23	220
Material		Aluminum		

STANDARD CONFIGURATION

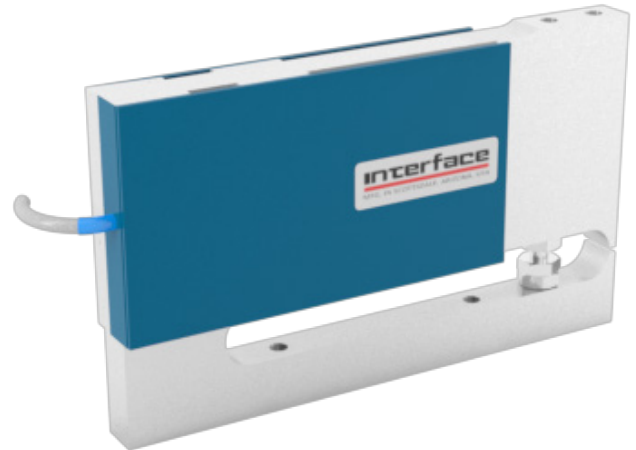

Model SPI (Shown)

OPTIONS

- Standardized output
- Custom calibration
- Transducer Electronic Data Sheet (TEDS)
- Add connector to cable
- Special temperature range

ACCESSORIES

- Instrumentation

CONNECTOR OPTIONS

- 5 ft (1.5 m) integral cable

International System of Units (SI) dimensions and capacities are provided for conversion only. Standard products have U.S. capacities and dimensions. SI capacities available upon special request and at an additional cost.

* Consult factory for more technical information

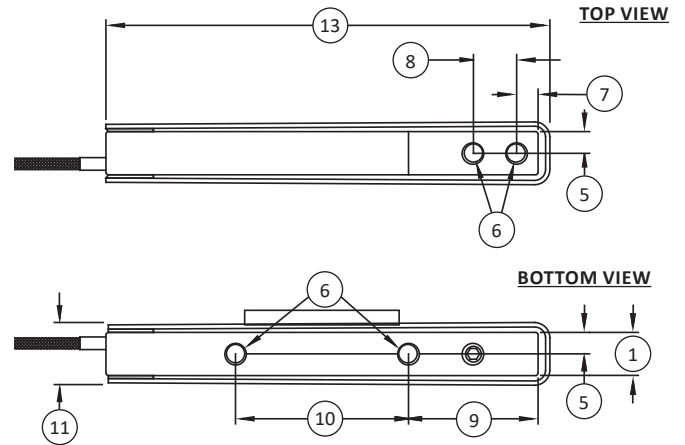
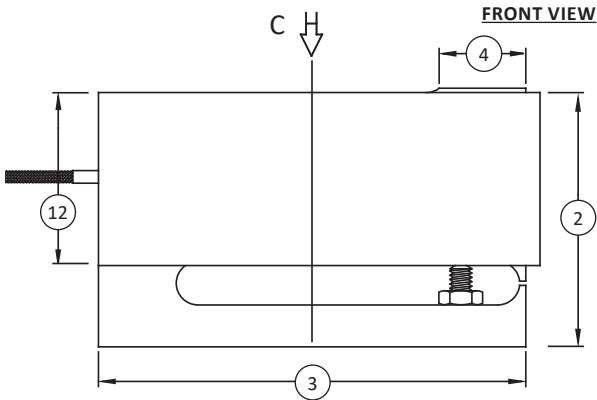

Notes:
* C indicates compression load direction / primary axis

DIMENSIONS

See Drawing	CAPACITY					
	U.S. (lbf)	Metric (N)	U.S. (lbf)	Metric (N)	U.S. (lbf)	Metric (N)
	3	13.3	7.5	33.4	15	66.7
	in	mm	in	mm	in	mm
(1)	0.38	9.60	0.50	12.7	1.00	25.4
(2)	2.99	75.9	2.99	75.9	2.99	75.9
(3)	5.00	127	5.00	127	5.00	127
(4)	1.00	25.4	1.00	25.4	1.00	25.4
(5)	0.19	4.80	0.25	6.40	0.5	12.7
(6)	10-32 UNF-2B \downarrow 0.50	10-32 UNF-2B \downarrow 12.7	$\frac{1}{4}$ -28 UNF-2B \downarrow 0.56	$\frac{1}{4}$ -28 UNF-2B \downarrow 14.2	$\frac{1}{4}$ -28 UNF-2B \downarrow 0.56	$\frac{1}{4}$ -28 UNF-2B \downarrow 14.2
(7)	0.25	6.40	0.25	6.40	0.25	6.40
(8)	0.50	12.7	0.50	12.7	0.50	12.7
(9)	1.50	38.1	1.50	38.1	1.50	38.1
(10)	2.00	50.8	2.00	50.8	2.00	50.8
(11)	0.62	15.7	0.75	19.0	1.25	31.8
(12)	2.00	50.8	2.00	50.8	2.00	50.8
(13)	5.13	130.3	5.13	130.3	5.13	130.3

FEATURES & BENEFITS

- Capacities: 111, 222, 445, 667 N
- Proprietary Interface temperature compensated strain gages
- 0.01% non-repeatability
- Safe overload to 200%
- 0.0015%/°C temp. effect on output
- Eccentric load compensated

SPECIFICATIONS

ACCURACY – (MAX ERROR)				
Nonlinearity – %FS		±0.02		
Hysteresis – %FS		±0.02		
Nonrepeatability – %RO		±0.01		
Creep, in 20 min – %		±0.025		
Eccentric Load Sensitivity – % / in		0.012		
TEMPERATURE				
Compensated Range	°F	+15 to +115		
	°C	-10 to +45		
Operating Range	°F	-65 to +200		
	°C	-55 to +90		
Effect on Output – % / deg	°F	±0.0008		
Effect on Zero – %RO / deg	°F	±0.0015		
ELECTRICAL				
Rated Output – mV/V (Nominal)		3.0		
Zero Balance – %RO		±5.0		
Bridge Resistance – Ohm (Nominal)		350		
Excitation Voltage – VDC MAX		15		
Insulation Resistance – Megohm		5000		
MECHANICAL				
Calibration		Compression		
Safe Overload – %CAP		200		
NATURAL FREQUENCY/DEFLECTION				
lbf	N	Deflection		Nat. Freq. – Hertz
		in	mm	
25	111	0.008	0.20	240
50	222	0.008	0.20	310
100	445	0.007	0.18	470
150	667	0.005	0.13	580
Material		Aluminum		

STANDARD CONFIGURATION

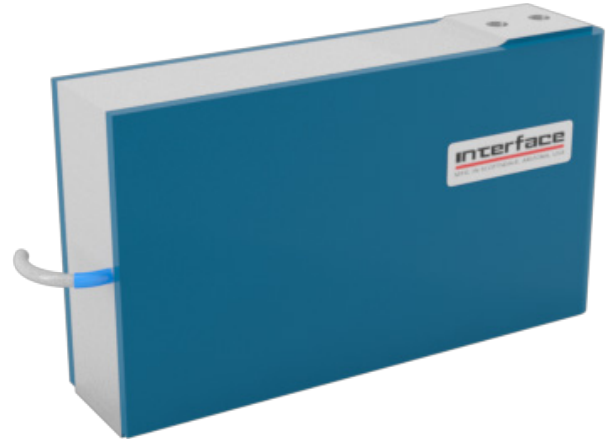

Model SPI (Shown)

OPTIONS

- Cable length
- Standardized output
- Transducer Electronic Data Sheet (TEDS)
- Special temperature range
- Add connector to cable

ACCESSORIES

- Instrumentation

CONNECTOR OPTIONS

- 5 ft (1.5 m) integral cable

International System of Units (SI) dimensions and capacities are provided for conversion only. Standard products have U.S. capacities and dimensions. SI capacities available upon special request and at an additional cost.

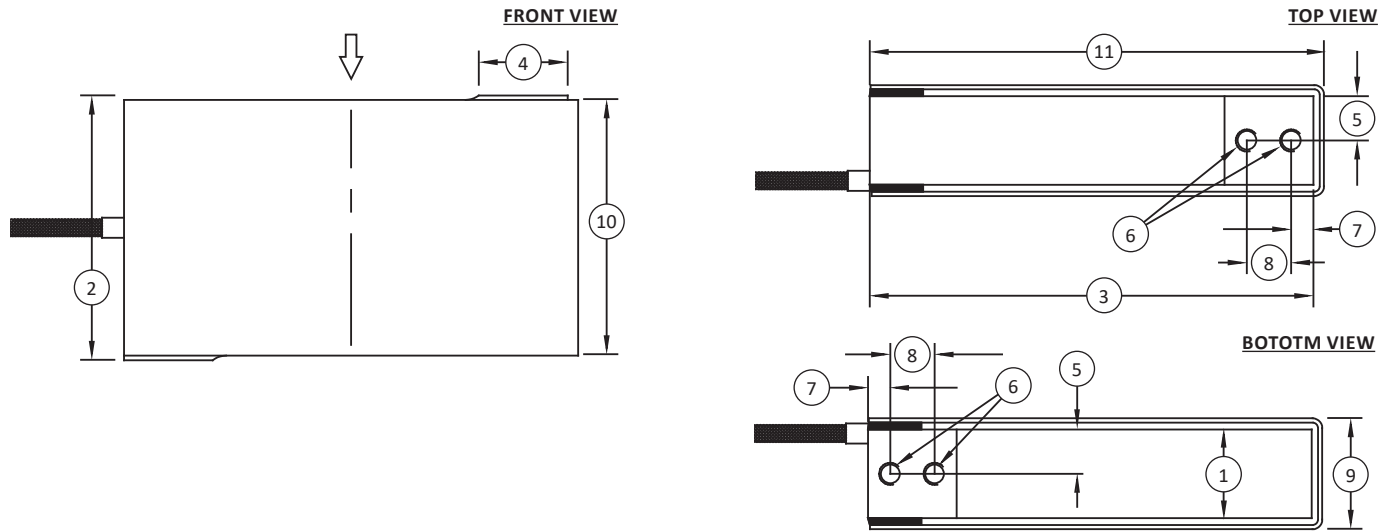

DIMENSIONS

See Drawing	CAPACITY			
	25, 50		100, 150	
	U.S. (lbf)	Metric (N)	U.S. (lbf)	Metric (N)
	25, 50	111, 222	100, 150	445, 667
	in	mm	in	mm
(1)	1.00	25.4	1.00	25.4
(2)	3.00	76.2	3.00	76.2
(3)	5.00	127	6.00	152.4
(4)	1.00	25.4	1.50	38.1
(5)	0.50	12.7	0.50	12.7
(6)	¼-28 UNF-2B ↓ 0.56	¼-28 UNF-2B ↓ 14.2	¼-28 UNF-2B ↓ 0.56	¼-28 UNF-2B ↓ 14.2
(7)	0.25	6.4	0.25	6.4
(8)	0.50	12.7	1.00	25.4
(9)	1.25	31.8	1.25	31.8
(10)	2.88	73.0	2.88	73.0
(11)	5.12	130	6.12	155.4