

### Features

- ❖ Two precisely matched sensors per channel give resolution to a nanometer.
- ❖ Superior thermal and long-term stability of 5x10<sup>-6</sup> inches/month or better.
- ❖ Small package size: 2 x 2.12 x 0.75 inches thick.
- ❖ Cryogenic sensors available.
- ❖ High sensitivity: up to 10 V/mil (394 mV/μm).
- ❖ Low power consumption: less than 2W @ ±15 Vdc typical.

### Differential Measurements

Differential measuring systems are a significant advance in precision measurement technology. They provide exceptional resolution, repeatability, and nulling accuracy for detecting the aligned/centered position of a conductive target relative to a pair of noncontacting sensors.

For differential measurement applications, two precisely matched sensors per channel are positioned on opposite sides or ends of a target. In this sensor-to-target relationship, as the target moves away from one sensor, it moves toward the other an equal amount. Output is differential and bipolar. The electronically-matched sensors on opposing legs of the same bridge provide superior thermal stability.

### Cryogenic Applications

Kaman builds an alternate version of the 20N sensor specifically for cryogenic applications. This sensor has internal expansion joints and, when screw mounted using a Belleville washer, effectively eliminates stress or temperature-induced mechanical distortions.

Kaman has confirmed optimum performance in liquid nitrogen at 70° Kelvin. Several aerospace applications make effective use of this sensor in a liquid helium environment at 4° K.



heat-sink compound and have been specified for orbital platforms.

### Vacuum Applications

Both sensor and KD-5100 electronics are used in vacuum applications down to 10<sup>-6</sup> Torr. KD-5100 systems use a NASA-certified

### KD-5100 Differential Super High-Precision System

The hybrid for the KD-5100 is manufactured to MIL-H-38534. MIL-SPEC components are utilized throughout the electronics module wherever possible. The KD-5100 features rugged construction with a mean time between failures of better than 55,000 hours in a tactical environment, 238,000 hours in a space flight environment.

The small package size of the KD-5100 (just 2 x 2.12 x 0.75 inches thick) makes this system ideal for applications where space is a limiting factor.



### Commercial Differential Systems

The DIT-5200 differential system is a commercial version of the KD-5100. This option significantly reduces the cost of a differential system when MIL-SPEC requirements, size,

weight, and power consumption are not critical.

### Examples of Current Applications

#### Relay Mirror Experiment

The Relay Mirror Experiment (RME) demonstrated that a laser beam can be accurately relayed from the earth to an orbiting satellite 450 kilometers away and then back to a 3-meter target on the ground. A free-flying spacecraft functions as the orbiting laser beam relay system. The objective was to validate the stabilization, tracking and pointing technologies at military performance levels through a credible demonstration of a space-based relay mirror system.

Kaman's KD-5100 differential sensors were used to precisely position the 60-centimeter relay mirror on the spacecraft payload to reflect the beams back to the target site. The KD-5100 was instrumental in achieving relay laser beam pointing accuracy that was 16 times better than the experimental goal and line-of-sight stabilization that was 2.3 times better.

#### Other Applications

- Night vision systems.
- Precision telescope positioning.
- Fast steering mirrors
- Image stabilization systems

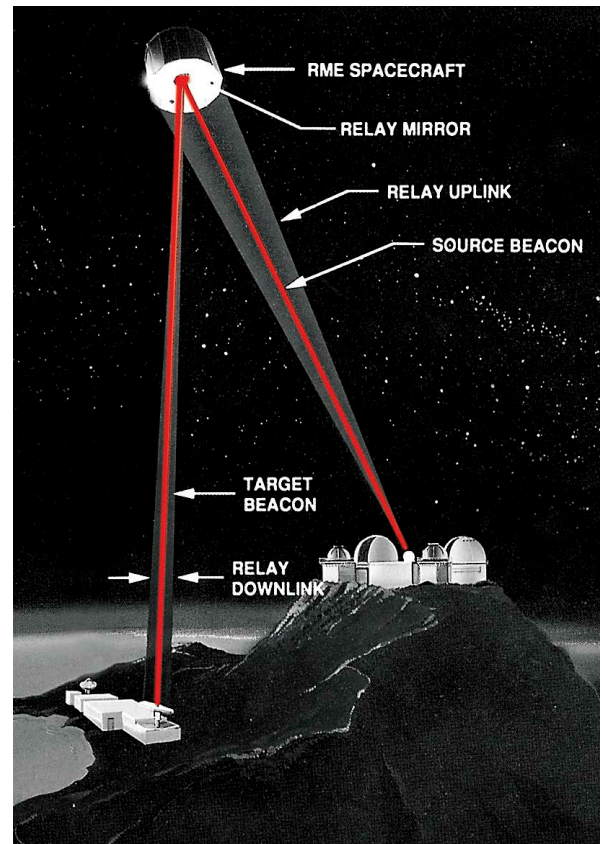

#### Super Precise Laser Focusing

Laser microcolumn technology is being used to develop direct-write applications in semiconductor wafer manufacturing. Microcolumn architecture uses laser devices with column lengths of several millimeters, and offers high resolution, miniaturization, and new source technology possibilities.

The technology is being used to develop both direct write applications and high-throughput mask patterning applications, and is being incorporated into products around the 0.1 micron generation.

Kaman's KD-5100 sensors are used in this technology to precisely position the laser to allow exceptionally fine placement, critical dimensions, and alignment control.

**Differential Sensors for KD-5100**

Two standard sensor configurations are available. The sensor model number is a suffix to the system designation.

15N: Smooth body 0.188-inch diameter (0.172-inch for 004).

20N: 0.4-inch diameter base mount.

In cases where the sensors are opposing, aluminum target thickness must be at least 0.05 inch to prevent sensor interaction.

15N sensor

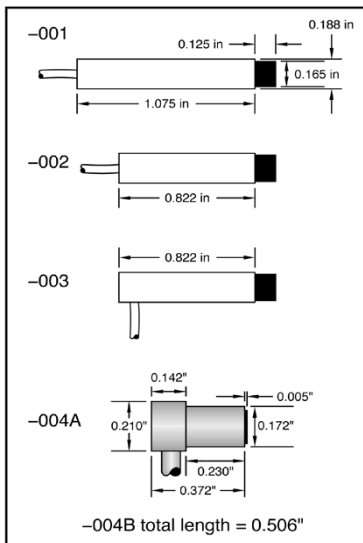

20N sensor

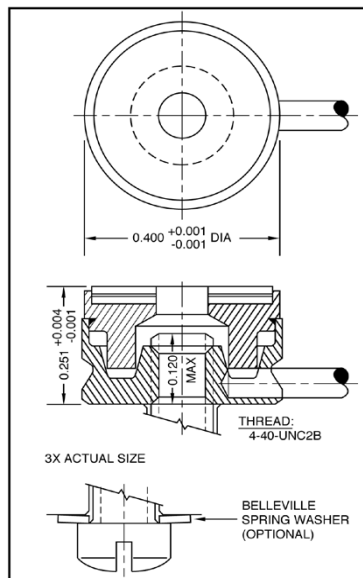

**Performance Specifications for an Aluminum Target**

Measuring range	15N	Up to ±0.035 inch (±0.9 mm)
	20N	Up to ±0.075 inch (±1.9 mm)
Nonlinearity		±0.1% to ±0.5% FSO; application dependent.
Output		±10 Vdc maximum
Long-term stability		(nominal; stabilized at 70°F [21°C] scale factor dependent) 5 x 10 <sup>-6</sup> inches/month (1.27 x 10 <sup>-4</sup> mm/month)
Thermal sensitivity		at null; application dependent; <5 mV per °F.
Frequency response		22 kHz ±5% @ 3 db
RMS input displacement resolution		(if bandwidth limited to 5 kHz): 4x10 <sup>-9</sup> x √bandwidth in Hz = in. 1x10 <sup>-7</sup> x √bandwidth in Hz = mm noise higher in KDM-8200
Input voltage		±15 Vdc @ 55 mA typical
Power consumption		<2 watts - system
Power dissipation		<0.5 mW per 15N sensor; <1.5 mW per 20N sensor
Output characteristics		<5 W @ 5 mA.
Operating temperature range	Electronics:	-4°F to +140°F (-20°C to +60°C)
	Sensors	-62°F to +220°F (-52°C to +105°C)
	Cryogenic 20N sensor	+4°K to +220°F (+105°C).
Storage temperature range	Electronics	-26°F to +180°F (-32°C to +82°C)
	Sensors	-62°F to +220°F (-52°C to +105°C)
	Cryogenic 20N sensor	+4°K to +220°F (+105°C)
Weight (with 5-foot cable)	Electronics	2.5 ounces (70 grams).
	15N-001 sensor	0.61 ounces (17.3 gram)
	20N sensor	0.59 ounces (16.8 grams)

**Custom Configurations**

Sensors and electronics packaging can be reconfigured for special customer applications or OEM requirements.

**Ordering Information**

Please refer to the price sheet for pricing of standard systems. Contact Kaman for a quotation on custom designs.