

RIPS® P503 FLAT ROTARY SENSOR

High-resolution angle feedback for industrial and scientific applicator

- **Non-contacting inductive technology to eliminate wear**
- **Angle set to customer's requirement**
- **Compact PCB design, durable and reliable**
- **High accuracy and stability**

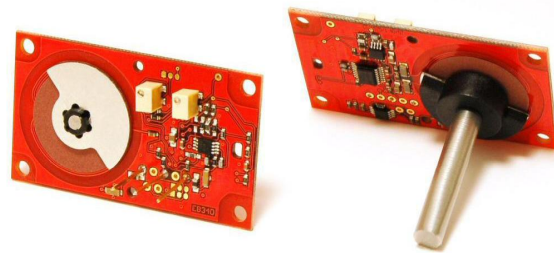

As a leading designer and manufacturer of linear, rotary, tilt and intrinsically safe position sensors, Positek® has the expertise to supply a sensor to suit a wide variety of applications.

The P503 RIPS® (Rotary Inductive Position Sensor) is a low-cost assembly designed particularly for OEM users.

Like all Positek® sensors it provides a linear output proportional with angle of rotation. Each unit is supplied with the output calibrated to the angle required by the customer, between 15 and 160 degrees.

With suitable mounting and bearings, overall performance, repeatability and stability are outstanding over a wide temperature range.

This very compact sensor, supplied as a printed circuit board sub-assembly, has a range of electrical options.

The P503 is ready to mount directly in customer's equipment. Connections to the sensor are made via solder pins.

SPECIFICATION

Dimensions	
Board Outline	56 x 32 x 6 mm standard
Board Outline	56 x 32 x 12.5 mm buffered
Shaft	31 mm Ø 6mm
For full mechanical details see drawing P503-11	
Independent Linearity	≤ ± 0.5% FSO @ 20°C - up to 100°
Temperature Coefficients	< ± 0.01%/°C Gain & < ± 0.01%FS/°C Offset
Frequency response	> 10 kHz (-3dB) > 300 Hz (-3dB) 2 wire 4 to 20 mA
Resolution	Infinite
Noise	< 0.02% FSO
Torque	< 20 mNm Static
Environmental Temperature Limits	
Operating	-40°C to +125°C standard -20°C to +85°C buffered -40°C to +125°C
Storage	-40°C to +125°C
Sealing	IP00
Vibration	IEC 68-2-6: 10 g
Shock	IEC 68-2-29: 40 g
MTBF	350,000 hrs 40°C Gf
Drawing List	
P503-11	Sensor Outline
Drawings, in AutoCAD® dwg or dxf format, available on request.	

Do you need a position sensor made to order to suit a particular installation requirement or specification? We'll be happy to modify any of our designs to suit your needs - please contact us with your requirements.



RIPS® P503 FLAT ROTARY SENSOR

High-resolution angle feedback for industrial and scientific applications

How Positek's PIPS® technology eliminates wear for longer life

Positek's **PIPS®** technology (Positek Inductive Position Sensor) is a major advance in displacement sensor design. PIPS®-based displacement transducers have the simplicity of a potentiometer with the life of an LVDT/RVDT.

PIPS® technology combines the best in fundamental inductive principles with advanced micro-electronic integrated circuit technology. A PIPS® sensor, based on simple inductive coils using Positek's ASIC control technology, directly measures absolute position giving a DC analogue output signal. Because there is no contact between moving electrical components, reliability is high and wear is eliminated for an exceptionally long life.

PIPS® overcomes the drawbacks of LVDT technology – bulky coils, poor length-to-stroke ratio and the need for special magnetic materials. It requires no separate signal conditioning.

Our LIPS® range are linear sensors, while RIPS® are rotary units and TIPS® are for detecting tilt position. Ask us for a full technical explanation of PIPS® technology.

We also offer a range of ATEX-qualified intrinsically-safe sensors.

TABLE OF OPTIONS

CALIBRATED TRAVEL: Factory-set to any angle from $\pm 7.5^\circ$ to $\pm 80^\circ$ in increments of 1 degree.
Full 360° Mechanical rotation.

ELECTRICAL INTERFACE OPTIONS

OUTPUT SIGNAL	SUPPLY INPUT	OUTPUT LOAD
Standard: 0.5-4.5V dc ratiometric	+5V dc nom. \pm 0.5V.	5k Ω min.
Buffered: 0.5-4.5V dc	+24V dc nom. + 9-28V.	5k Ω min.
\pm 5V dc	\pm 15V dc nom. \pm 9-28V.	5k Ω min.
0.5-9.5V dc	+24V dc nom. + 13-28V.	5k Ω min.
\pm 10V dc	\pm 15 V dc nom. \pm 13.5-28V.	5k Ω min.
Supply Current	10mA typical, 20mA maximum.	
4-20mA (2 wire)	+24 V dc nom. + 18-28V.	300 Ω @ 24V.
(3 wire sink)	+24 V dc nom. + 13-28V.	950 Ω @ 24V.
(3 wire source)	+24 V dc nom. + 13-28V.	300 Ω max.

Sensors supplied with access to output 'zero' and 'span' calibration adjustments as standard.

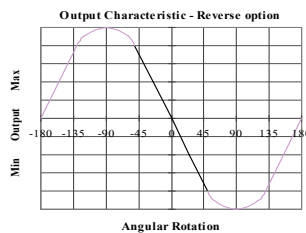
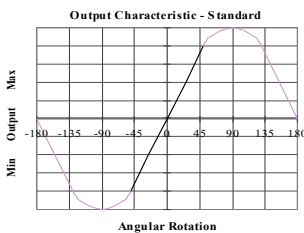

RIPS[®] SERIES P503 Flat Rotary Sensor



a Displacement (degrees)		Value
Displacement in degrees	e.g. 0 - 54 degrees	54
b Output		
Supply V dc V _s (tolerance)	Output	Code
+5V (4.5 - 5.5V)	0.5 - 4.5V (ratiometric with supply)	A
±15V nom. (±9 - 28V)	±5V	B
+24V nom. (13 - 28V)	0.5 - 9.5V	C
±15V nom. (±13.5 - 28V)	±10V	D
+24V nom. (18 - 28V)	4 - 20mA 2 wire	E
+24V nom. (13 - 28V)	4 - 20mA 3 wire Sink	F
+24V nom. (9 - 28V)	0.5 - 4.5V	G
+24V nom. (13 - 28V)	4 - 20mA 3 wire Source	H



Installation Information

RIPS® P503 FLAT ROTARY SENSOR ASSEMBLY

Output Option	Output Description:	Supply Voltage: V_s (tolerance)	Load resistance: (include leads for 4 to 20mA O/Ps)
A	0.5 - 4.5V (ratiometric with supply)	+5V (4.5 - 5.5V)	$\geq 5k\Omega$
B	$\pm 5V$	$\pm 15V$ nom. ($\pm 9 - 28V$)	$\geq 5k\Omega$
C	0.5 - 9.5V	+24V nom. (13 - 28V)	$\geq 5k\Omega$
D	$\pm 10V$	$\pm 15V$ nom. ($\pm 13.5 - 28V$)	$\geq 5k\Omega$
E	4 - 20mA 2 wire Current Loop	+24V nom. (18 - 28V)	$\approx 0 - 300\Omega$ max. @24V ~ 1.2 to 6V across 300 Ω $\{R_L \text{ max.} = (V_s - 18) / 20^{-3}\}$
F	4 - 20mA 3 wire Sink	+24V nom. (13 - 28V)	$\approx 0 - 950\Omega$ max. @24V ~ 3.8 to 19V across 950 Ω $\{R_L \text{ max.} = (V_s - 5) / 20^{-3}\}$
G	0.5 - 4.5V	+24V nom. (9 - 28V)	$\geq 5k\Omega$
H	4 - 20mA 3 wire Source	+24V nom. (13 - 28V)	$\approx 0 - 300\Omega$ max. ~ 1.2 to 6V across 300 Ω

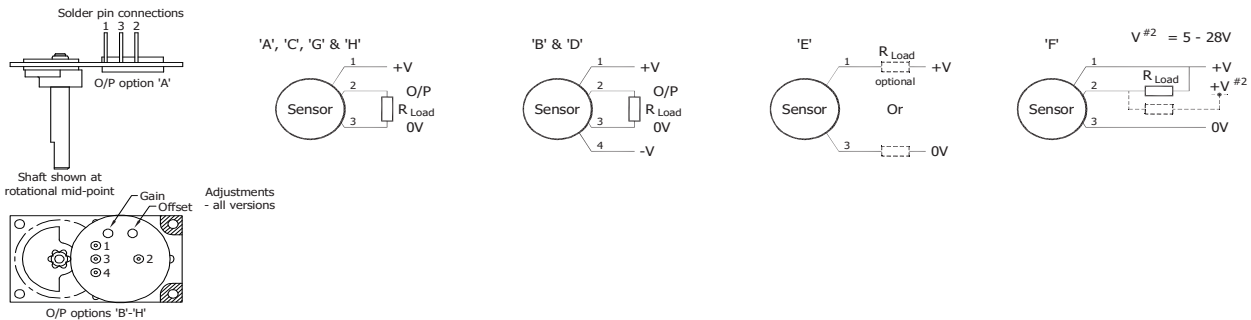

Gain and Offset Adjustment: (Typically $\pm 10\%$ Min available)

To adjust the gain or offset use a small potentiometer adjuster or screwdriver 2mm across. Do not apply too much force on the potentiometers. The offset is set at mid span at the mid point, within $\pm 5^\circ$, of rotation.

Mechanical Mounting: By four 3.2 mm diameter holes in the printed circuit board. The sensor should be mounted with minimal axial and radial loading on the shaft for optimum life. It is recommended that the shaft is coupled to the drive using a flexible coupling. Tests indicate that, with a suitable bearing system, a life in excess of 16 million cycles can be achieved with 1kg side and end load. The radial position of the shaft must be controlled by the customer; the end float is set by the sensor and should not be controlled by the customer.

Output Characteristic: The sensor has full rotational freedom and two sectors, 180° apart, over which linear response can be achieved. At the mid point of the calibrated range the output signal will be half full scale deflection, and the flat on the shaft is as shown. In the calibrated range the output increases as the shaft is rotated in an anti-clockwise direction viewed from the shaft. The calibrated output is factory set to be between 15 and 160°.

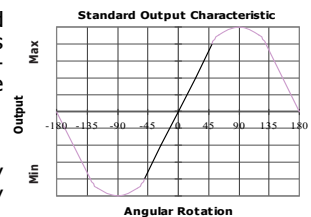

Incorrect Connection Protection levels:-

- A** **Not protected** – the sensor is **not** protected against either reverse polarity or over-voltage. The risk of damage should be minimal where the supply current is limited to less than 50mA.
- B & D** Supply leads diode protected. Output must not be taken outside $\pm 12V$.
- C & G** Supply leads diode protected. Output must not be taken outside 0 to 12V.
- E, F & H** Protected against any misconnection within the rated voltage.

STANDARD
(CODE 'A')

DIRECTION OF SHAFT
ROTATION FOR
INCREASING OUTPUT.

'X' GAIN ADJUSTMENT.
OFFSET ADJUSTMENT.

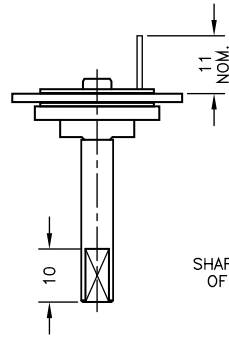
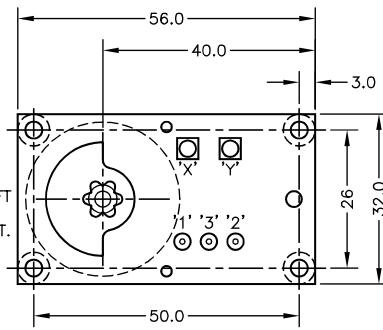

SHAFT SHOWN AT CENTRE
OF CALIBRATED RANGE

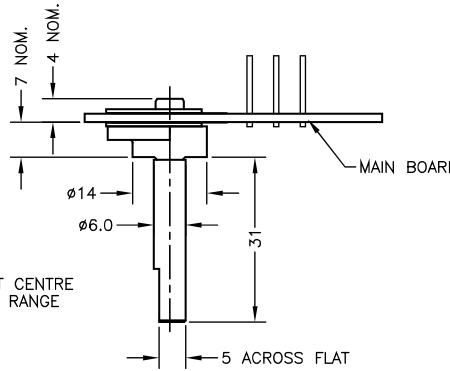

BUFFERED
(CODES 'B' - 'H')

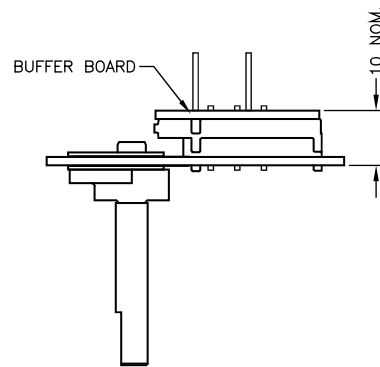
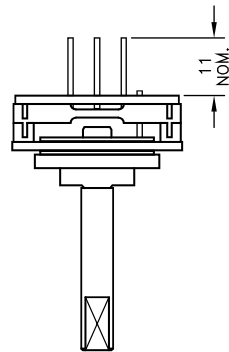
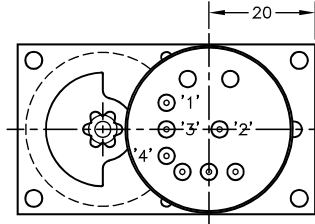

ELECTRICAL OPTIONS/ SPECIFICATIONS

OUTPUT OPTION	OUTPUT	SUPPLY	
A	0.5 TO 4.5V RATIOMETRIC	5V	STANDARD
B	±5V	±15V	
C	0.5 TO 9.5V	24V	BUFFERED
D	±10V	±15V	
E	0.5 TO 4.5V	24V	BUFFERED
F	SUPPLY CURRENT 12mA TYP. 20mA MAX.	24V	
G	4 TO 20mA 2-WIRE	24V	BUFFERED
H	4 TO 20mA 3-WIRE SINK	24V	
	4 TO 20mA 3-WIRE SOURCE	24V	
	SINK VERSION OUTPUT COMPLIANCE 5-28V		
	SOURCE VERSION DRIVE 300Ω MAX TO 0V		

SOLDER PINS

- :1 +Ve
- :2 OUTPUT
- :3 0V
- :4 -Ve - OPTIONS: B OR D

RANGE OF DISPLACEMENT FROM 0-15° TO 0-160° e.g. 76°, IN INCREMENTS OF 1°.

SHAFT MATERIAL:- STAINLESS STEEL.
PCB MATERIAL:- FR-4, 1.6mm THICK.

MOUNTING NOTES:

MAIN AND BUFFER CIRCUIT BOARDS ARE DOUBLE SIDED, ALLOW 3.5mm FROM BOARD SURFACES FOR COMPONENTS. 4 Ø3.2 MOUNTING HOLES WITH Ø6 CLEARANCE - BOTH SIDES. THE RADIAL POSITION OF THE SHAFT MUST BE CONTROLLED BY THE CUSTOMER.

THE END FLOAT OF THE SHAFT IS SET BY THE SENSOR AND SHOULD NOT BE CONTROLLED BY NOT BE CONTROLLED BY THE CUSTOMER.

H	REDRAWN, OPTIONS B & G ADDED.	PDM
I	HUB ROTATED 180 - RAN200	PDM
J	HUB ORIENTATION AS REV H - RAN257	PDM
K	PINS ADDED- RAN281	RDS
L	ADDITIONAL DIMS/VIEWS ADDED.	PDM
M	DISP. 15 TO 160° WAS 20 TO 160° RAN442.	PDM
N	RANGE NOTE AMENDED ~ RAN1200	PDM

DRAWINGS NOT TO BE CHANGED WITHOUT REFERENCE TO THE CHANGE PROCEDURE. CHANGES TO PARTS USED IN INTRINSICALLY SAFE PRODUCT MUST BE APPROVED BY THE AUTHORISED PERSON
THIS IS AN UNCONTROLLED PRINT AND WILL NOT BE UPDATED.



H	06/10/06	CHECKED BY X RDS	X	±0.4
I	18/02/08		X.X	±0.2
J	24/11/09		X.XX	±0.1
K	21/07/10	DESCRIPTION		
L	06/07/11	P503 RIPS FLAT ROTARY		
M	20/11/13	SENSOR ASSEMBLY		
N	12/09/17			
SCALE 10mm		DRAWING NUMBER P503-11	REV	N
SHEET			1	OF