



Description

The multi-component sensor F6D45 is used for force and torque measurement in three mutually perpendicular axes.

The multi-component sensor F6D45 is equipped with fastening flanges according to DIN EN ISO 9409-1 for industrial robots. The measuring flange of the sensor contains tapped holes M3 on the same pitch circle. The F6D force / torque sensor can be mounted to the robot flange without additional adapters, making it particularly flat and light compared to the K6D series sensors.

The evaluation of the force and moment load is carried out with an external measuring amplifier GSV-8DS SubD44HD or GSV-8AS.

The sensors are made of an aluminum alloy.

Our robotics partner IPR offers solutions for applications of force / torque sensors.

Dimensions

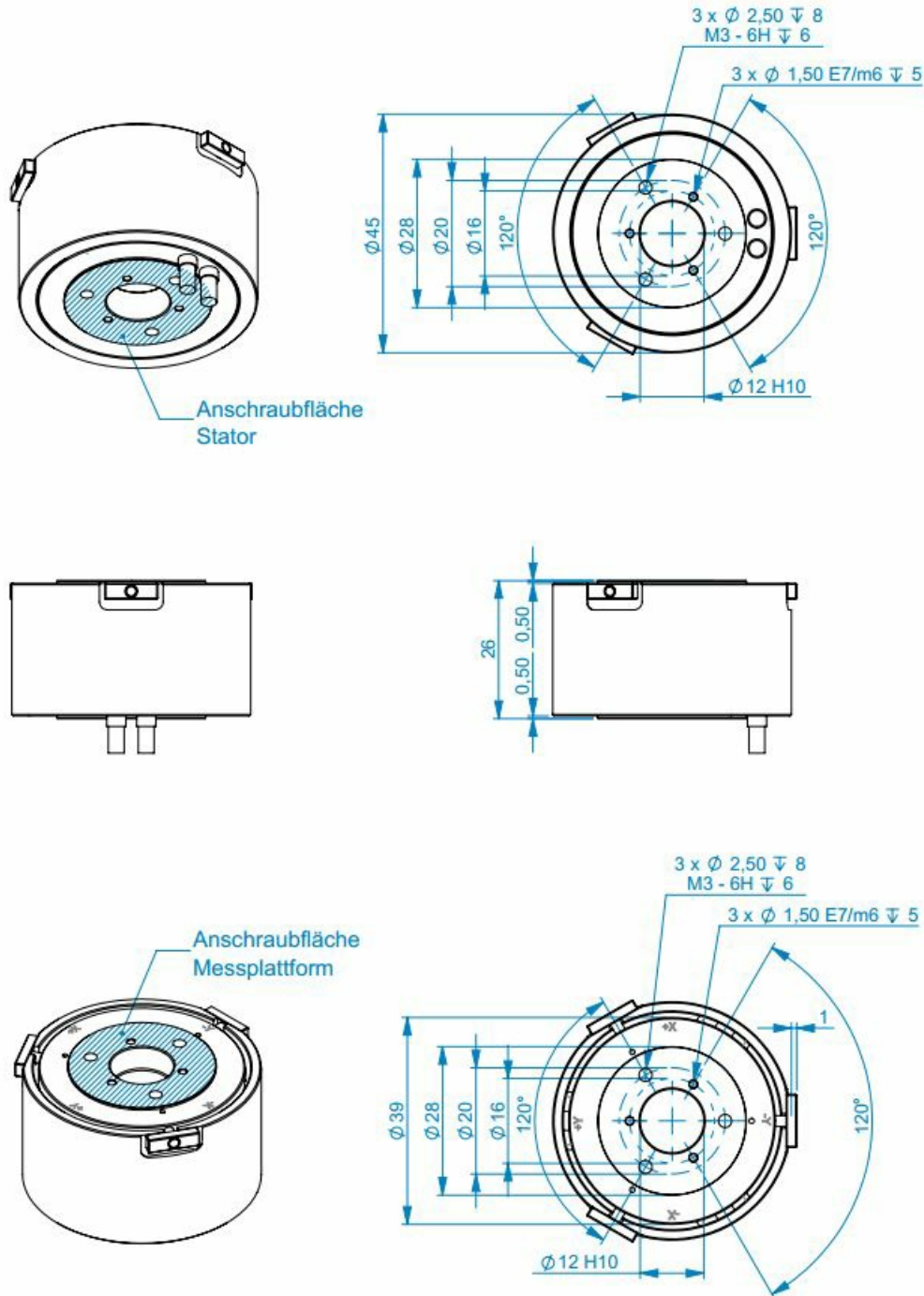

Technical Data

Force sensor

Type	6-Axis force sensor
Force direction	Tension / Compression
Rated force Fx	20 N
Rated force Fy	20 N
Rated force Fz	50 N
Force introduction	Inner thread
Dimension 1	3xM3
Sensor Fastening	Inner thread
Operating force	300 %FS
Rated displacement	0.05 mm
Twist	0.04 rad
Material	Aluminium alloy
Height	26 mm
Length or Diameter	45 mm
Rated torque Mx	1 Nm
Rated torque My	1 Nm
Rated torque Mz	1 Nm
Breaking force	600 %FS

Electrical Data

Input resistance	1000 Ohm
Tolerance input resistance	50 Ohm
Output resistance	1000 Ohm
Tolerance output resistance	50 Ohm
Insulation resistance	2 GOhm
Rated range of excitation voltage f	2.5 ... 5 V
Operating range of excitation voltage f	1 ... 10 V
Zero signal	1 mV/V
Rated output	0.4 mV/V / FS

Precision

Accuracy class	1%
Relative linearity error	0.1 %FS
Relative zero signal hysteresis	0.1 %FS
Temperature effect on zero signal	0.1 %FS/K
Temperature effect on characteristic value	0.05 %RD/K
Relative creep	0.1 %FS
Relative repeatability error	0.5 %FS

Connection Data

Connection type	12 conductor open
Name of the connection	Kabeldurchführung (CG) mit 2x 3m 30-12 PUR / 12x0,061mm ² ;

Rated temperature range f	-10 ... 70 °C
Operating temperature range f	-10 ... 85 °C
Storage temperature range f	-10 ... 85 °C
Environmental protection	IP64

Abbreviation : RD: „Reading“; FS: „Full Scale“;

The application of a calibration matrix is required for the determination of the forces F_x , F_y , F_z and moments M_x , M_y , and M_z from the 6 measurement channels, and to compensate for the crosstalk.

The calibration data are individually determined and documented for the sensor.

The measurement error is expressed individually by the specification of the extended measurement uncertainty ($k = 2$) for the forces F_x , F_y , F_z , and moments M_x , M_y , M_z .

Manual

Stiffness matrix F6D80-40 100N/10Nm

36.6 kN/mm	0.0	0.0	0.0	348 kN	0.0	u_x
0.0	36.6 kN/mm	0.0	-348 kN	0.0	0.0	u_y
0.0	0.0	357.9 kN/mm	0.0	0.0	0.0	u_z
0.0	-348 kN	0.0	199.0 kNm	0.0	0.0	ϕ_{ix}
348 kN	0.0	0.0	0.0	199.0 kNm	0.0	ϕ_{iy}
0.0	0.0	0.0	0.0	0.0	63.1 kNm	ϕ_{iz}

Stiffness matrix F6D80-40 300N/30Nm

103.0 kN/mm	0.0	0.0	0.0	979 kN	0.0	u_x
0.0	103.0 kN/mm	0.0	-979 kN	0.0	0.0	u_y
0.0	0.0	1004.8 kN/mm	0.0	0.0	0.0	u_z
0.0	-979 kN	0.0	55.6 kNm	0.0	0.0	ϕ_{ix}
979 kN	0.0	0.0	0.0	558.6 kNm	0.0	ϕ_{iy}
0.0	0.0	0.0	0.0	0.0	17.0 kNm	ϕ_{iz}

Element	Description of the context
[kN/mm]	force- displacement
[kNm]	torque- twist
[kN]	force- twist and torque- displacement

Mounting

Calibration matrix

The calibration matrix contains 36 calibration factors for calculating the forces and torques from the 6 output signals of the force sensor. A Labview vi is available for processing the calibration matrix

Measuring amplifier

The measuring amplifier GSV-8DS or GSV-8AS has 24-pole plug connector to connect the 6-axis force/torque sensor. The mechanical forces and torques are calculated from 6 output voltages of each measuring channel with the calibration matrix.

Software

The GSVmulti software is included in delivery with measuring amplifiers GSV-8. The software allows the application of the calibration matrix and the displacement of the coordinate system to represent the torques around a freely selectable reference point.

To create your own software, a Labview VI is available.

Mounting instruction

The force is applied to a circular ring (Ø80-Ø40) on the live end of the sensor. The area inside the circular ring remains unloaded.

3 centering hole Ø1,5 serves to secure the angular position.

3x M3 internal thread for mounting the tool (this flange corresponds again to the robot flange);

Robotics solutions from IPR





Our robotics partner IPR offers solutions for applications of force / torque sensors in the areas of

- Mounting and handling technology
- Machine loading
- Foundry and blacksmith
- Cavity preservation
- Sealing and damping
- Lack and paint
- Services

IPR - Intelligente Peripherien für Roboter GmbH
Industriestraße 29
74193 Schwaigern
Deutschland

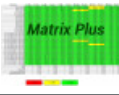
Tel: +49 7138 812-100
email: info@iprworldwide.com

accessories

Description	Description
	K6D-CalibrationMatrix SL Standard calibration matrix "Small load" for the sensors with small measuring ranges
	K6D-CalibrationMatrix SL/Plus High accuracy calibration matrix for 6-axis force/torque sensors;
	GSV-8DS 8-channel amplifier with USB port, analog output, UART interface. Other versions GSV-8AS CAN with Canbus and GSV-8AS EC with EtherCAT fieldbus.
	GSV-8AS 8-channel amplifier with USB port, analog output, 16x DIO, UART interface.
	Configuration D-Sub44/m/HD Assembling the connector to sensor cable; Connector Type SubD, 44 pins, male (male), with hood
	Configuration 24p/m/M16 Round plug, 24 pole, configured with sensor cable