

ASC P311K-A15 | ASC P311K-A25

Uniaxial
IEPE (Integrated Electronics Piezo-Electric)
Measurement Range: ± 16 to ± 800 g
Frequency Range (± 10 %): 1.5 Hz to 16 kHz
Scale Factor: 10 mV/g to 500 mV/g
Stainless-Steel Housing (IP68)



Industrial IEPE Accelerometer

Industrial IEPE accelerometers are based on the piezoelectric effect, where an input acceleration causes a force on the seismic mass which leads to a proportional charge generation within the ceramic PZT material. The IEPE (integrated electronics piezo-electric) circuitry features the conversion of the charge to an analog voltage output signal. As opposed to capacitive accelerometers this signal has a high-pass characteristic, which enables highly dynamic measurements with a very high bandwidth of up to 16 kHz (± 10 %) even without the detection of static DC components. Further advantage of piezoelectric accelerometers is a high operating temperature range from -55 °C up to $+150$ °C.

Description

Piezoelectric accelerometers are based on PZT ceramic and feature a built-in preamplifier and a charge to voltage converter. The industrial accelerometers providing a very high full-scale output voltage of ± 8 V and low broadband noise of <100 μ g. The sensors operate on a constant-current supply and use a simple two-wire coaxial cable for power input and signal output.

The accelerometers feature a robust stainless-steel housing with protection class IP68, different mounting options and a detachable cable with configurable length and connectors.

The uniaxial piezoelectric accelerometers ASC P311K-A15 (side connector) and ASC P311K-A25 (top-connector) are ideal suited for industrial applications: condition monitoring of wind turbines and their components as well as predictive maintenance of machinery as part of the smart factory.

Features

- Shear Type
- Side-Connector or Top-Connector Entry
- AC Response
- High Resonance Frequency
- High Shock Resistance

Options

- Detachable Connector Cables
- Different Mounting Options
- Enhanced Tolerance of the Scale Factor (± 5 %)

Applications

- Condition Monitoring
- Renewable Energy
- Industrial Applications

More applications in several markets are figured out on our web page www.asc-sensors.de

ASC P311K-A15 (Side-Connector)

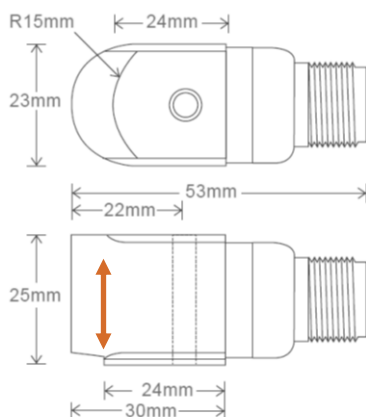

Connection Details (2-pin MS)

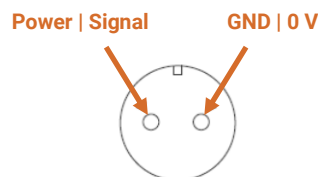

ASC P311K-A25 (Top-Connector)

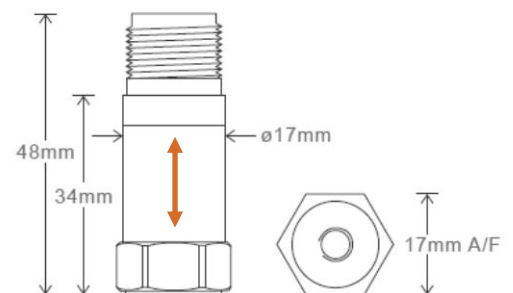

Typical Specification
Dynamic

Measurement Range	g	±16	±32	±80	±160	±250	±800
Scale Factor, Sensitivity (±10 %), (±5 % on request, see ordering information)	mV/g	500	250	100	50	30	10
Broadband Noise (max)	mg	0.1					
Specified Frequency Response Range (±5 %)	Hz	2.0 to 14000					
Specified Frequency Response Range (±10 %)	Hz	1.5 to 16000					
Frequency Response Range (±3 dB)	Hz	0.8 to 19000					
Resonance Frequency ASC P311K-A15	kHz	20	22	24	26	28	30
Resonance Frequency ASC P311K-A25	kHz	24	26	28	30	32	34
Transverse Sensitivity	%	<5					

Electrical

Power Supply Voltage	V	18 to 30					
Constant Supply Current	mA	0.5 to 8					
Offset (bias)	V	10 to 12					
Settling Time	s	1					
Output Impedance (max)	Ω	200					
Insulation Resistance (min at 500 V)	MΩ	100					
Isolation		Case Isolated					

Environmental

Operating Temperature Range	°C	-55 to +150					
Storage Temperature Range	°C	-55 to +150					
Shock Limit	g	5000					
Protection Class		IP68					

Physical

Sensing Element Type	PZT Shear						
Case Material	Stainless-Steel						
Connector	2-pin MS						
Mounting ASC P311K-A15	Adhesive Hexagonal Head Mounting Bolt (30 mm long)						
Mounting Thread Options ASC P311K-A15	¼-28" UNF Male M6 x 1 mm Male M8 x 1.25 mm Male						
Mounting ASC P311K-A25	Adhesive Screw Studs (¼-28" UNF male)						
Mounting Thread Options ASC P311K-A25	¼-28" UNF Male M6 x 1 mm Male M8 x 1.25 mm Male M10 x 1.5 mm Male						
Mounting Torque	Nm	8					
Weight (without cable)	gram	ASC P311K-A15: 135 ASC P311K-A25: 52					
Cable (order separately)	See Accessories						

Ordering Information

Series	Model	-	Options	-	Scale Factor [mV/g]
ASC P	311K-A15 (Side-Connector)		Y (Enhanced Scale Factor Tolerance of ±5 %)		010
	311K-A25 (Top-connector)				030
					050
					100
					250
					500

Example:

ASC P311K-A15-Y-010

Ordering information are based on standard configurations. All customized versions will lead to a corresponding product match code:

- There are different options regarding the connector of the sensor housing as well as different mounting accessories. Please contact us for further information.
- Sinusoidal factory calibration is supplied with the sensor. If any other calibration procedure is required, don't hesitate to contact us. Furthermore, sensors have to be calibrated regularly to ensure accurate and precise results. On request we will be glad to remind you of the next scheduled calibration of your sensors.

Accessories

Cable	-	Type (Material, Temperature Range)	-	Cable Length [m]	-	Connector
ASC KPI		1 (PUR, -40 °C to +90 °C)		005		BNC
		3 (FEP, -80 °C to +200 °C)		010		
				015		
				025		

Example:

ASC KPI-1-005-BNC

The accelerometers are fabricated for operating with a detachable connector cable which is no part of the product and needs to be ordered separately. Ordering information are based on standard configurations. All customized versions will lead to a corresponding product match code:

- Standard are detachable connector cables based on Polyurethane (PUR) and Fluorethylenpropylen (FEP) which are highly abrasion and tear resistant, waterproof and submersible (protection class IP68), flexible as well as providing good resistance to oil and petrol.
- Different customized cable materials, lengths and connectors are available on request. Please contact us for further information.

Safety Precaution for Installing and Operating

This data sheet is a part of the product. Read the data sheet carefully before using the product and keep it available for future operation. Handling, electrical connections, mounting or any other work performed at the sensor must be carried out by authorized experts only. Appropriate safety precautions must be taken to exclude any risk of personal injury and damage to operating equipment as a result of a sensor malfunction.

Handling

The sensor is packaged in a reliable housing to protect the sensing elements and integrated electronic components from the ambient environment. However, poor handling of the product can lead to damages that may not be visible and cause electrical failure or reliability issues. Handle the component with caution:

- Avoid shocks and impacts on the housing, such as dropping the sensor on hard surface
- Never move the sensor by pulling the cable
- Make sure that the sensor is used within the specified environmental conditions
- Transport and store the sensor in its original or similar packaging
- The sensor should be mounted on a stable flat surface with all screws tightened or other mounting options
- Avoid any deformation during mounting the sensor
- Mounting tolerances may have an influence on the measured result

Electrical

ASC's inertial sensors are working with many established data acquisition systems. However, make sure that a proper DAQ is used, for the corresponding operation principle of the sensor. Furthermore, suitable precautions shall be employed during all phases of shipment, handling and operating:

- Active sensor pins are susceptible to damage due to electrostatic discharge (ESD)
- Make sure that the sensor is used within the specified electrical conditions
- Check all electrical connections prior to initial setup of the sensor
- Completely shield the sensor and connecting cable
- Do not perform any electrical modifications at the sensor
- Do not perform any adaptations on the wiring or connectors while the device under power
- Never plug or unplug the electrical connection while the sensor is under power
- When a certain pin is not used during operation, make sure that the pin is insulated

Quality

- We have a quality management system according to ISO 9001:2015.
- The Deutsche Akkreditierungsstelle GmbH (DAkkS) has awarded to our calibration laboratory the DIN EN ISO/IEC 17025:2018 accreditation for calibrations and has confirmed our competence to perform calibrations in the field of mechanical acceleration measurements. The pictured DAkkS-ILAC logo refers exclusively to the accredited service.
- All ASC products are **CE**-compliant.

Made in Germany



analyzing



monitoring



testing



measuring